



X-Design series are the flagship handles of OLFA utility knives which feature the X-shaped rubber grip. The shape of this grip makes it easy to apply force without slipping. The X-design handle is widely used by professionals around the world.



# PRODUCT GUIDE

OLFA's infinite imagination gives you  
new business possibilities.



# As the Originator

of the snap-off cutter knives,  
we are committed to developing  
unique and safe products.

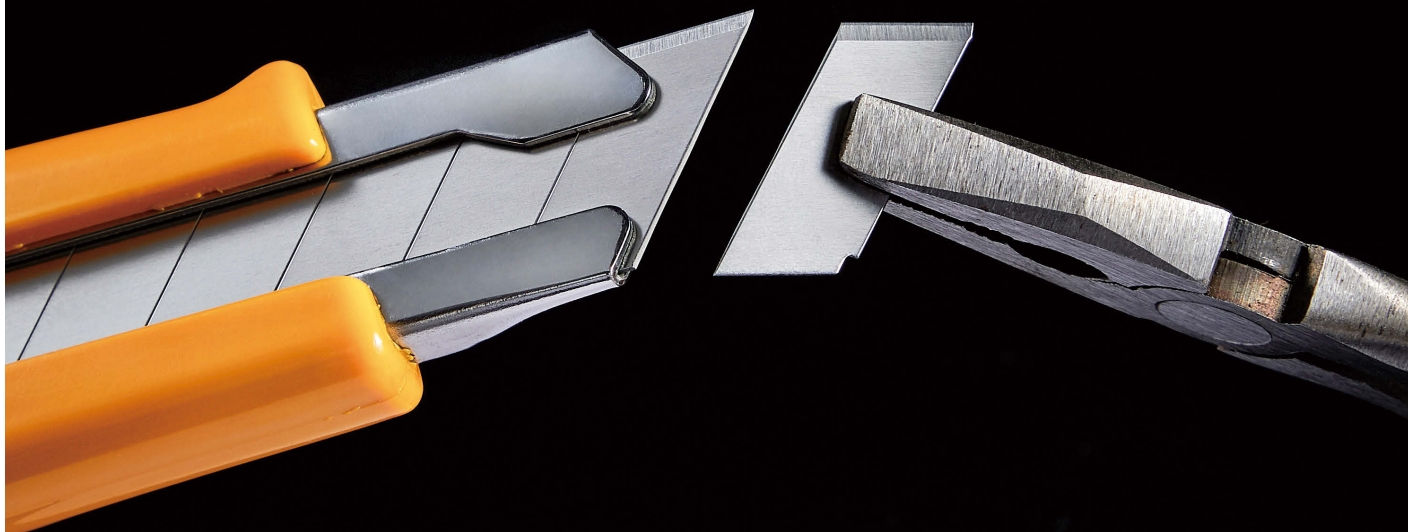

**1956**

The world's 1st  
SNAP-OFF BLADE CUTTER



**1979**

The world's 1st  
ROTARY CUTTER



Ever since inventing the world's first snap-off blade cutter in 1956, OLFA has created products such as the Rotary Cutter that can cut fabric by rolling a circular blade. Today, OLFA is the number 1 brand in Japan for cutter knives, and also exports to users that value high quality in over 100 countries and locations around the world.



The founder of  
OLFA CORPORATION

**Mr. Yoshio OKADA**  
(1931 - 1990)

THE  
OLFA  
HANDLE

*for  
your*  
**HANDS**



With a half century of striving  
for the most comfortable grip and blade sharpness,  
we deliver our result to the hands of users for many diverse situations.

"Safety" and "Security" always come first.



# POWER OF X



POWER  
OF X  
PAGE





# X-design Series



Designed with a rubber grip  
to prevent slipping while providing the best stability.

The X-Design series pursues to provide the best grip and stability when cutting.  
Experience the Made in Japan feel.



Extra Heavy-Duty

**XH-1**



Heavy-Duty

**L-5**



Medium-Sized

**XMT-1**



Standard-Duty

**XA-1**



Scraper

**XSR-200**



A proposal from OLFA for creating a safe working environment

# SAFETY FIRST™



**OLFA SK series**  
emphasizes safety and work efficiency.



Scan to learn more



How to use OLFA cutters properly



## Designed with Safety in Mind

Though knives are useful, they carry the risk of causing injury depending on how they are used.

If an injury were to occur, it could be damaging to a company in various ways, including in terms of production and compensation.

For this reason, more and more companies are restricting the use of utility knives due to the increased safety awareness in recent years.



Bag/Pack cutter

# PK-1

## Clip and Slide.

Start cutting from *anywhere* on the bag!



Easy to use



High durability



Long-lasting Sharpness

FOR BOTH  
RIGHT- and LEFT-  
HANDED USERS

STAINLESS  
STEEL  
BLADE



The Compact Safety Snap Knife  
For Beginners

# ESK-1



Symmetrical design.  
Just rotate the blade for left-  
or right-handed use.

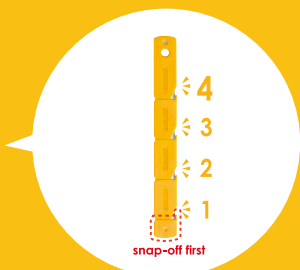

Fun easy-to-snap  
4-segment snap blades.



Plastic cover minimizes blade  
exposure for safety, and gives  
it a natural and stylish look.

※Use the dedicated snapper to  
snap off blades.

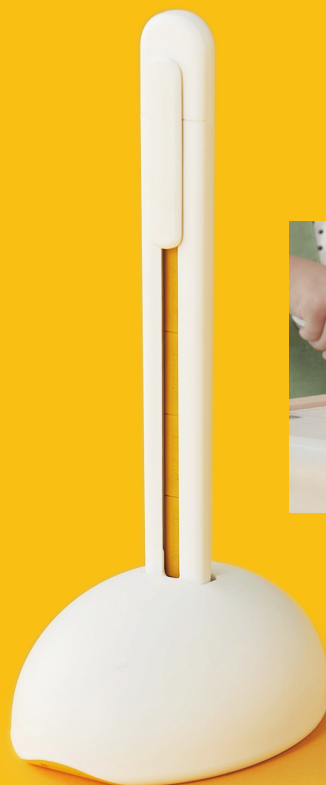

Three easy steps!

### Cut!



### Snap!



### Store!



INSTRUCTION MANUAL  
of the ESK-1

[www.olja.co.jp/en/manual](http://www.olja.co.jp/en/manual)



18  
mm

28  
mm

45  
mm

60  
mm



The world's first Rotary Cutter

# OLFA ROTARY CUTTER SINCE 1979

45+ years ago, the Rotary Cutter was created by OLFA and revolutionized the way people cut fabric.

12.5mm cutters are the ideal tool for a wide range of tasks.



18 mm

12.5 mm

9 mm

compact but  
**TOUGH**



**12.5**  
mm

**Bridges the gap**

Toughness of a 18mm blade and versatility of a 9mm, best of both worlds.



18 mm

9 mm

**EXCELBLACK**  
ULTRA SHARP BLADES OLFA

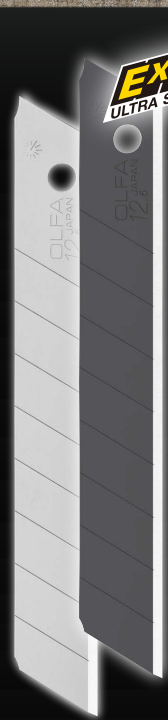

At OLFA, we provide eco-friendly products and simplified packing options to meet various needs.

# WOODYCUTTER



**WD-L/BRN WD-AL/BRN**



*Compared to all-plastic, the new biomass material is less slippery with oil on the hands!*



 **OLFA green™**



Environment-Friendly cutters made from recycled material

L-1/green



ES-1/green



SK-4/green



SK-7/green



**L-5**

MODEL NUMBER

NUMÉRO DU MODÈLE | MODELL NUMMER | NUMERO DE MODELO

LBB/LB/LBD/LB-SOL/  
LFB/LWB

220X95X25 (mm)

6X20 (pcs.)

Built-in hard metal pick for multi-purpose applications

- Conception-X, force de coupe supérieure.
- Pointe en métal dur intégrée pour applications polyvalentes
- X-Design, bessere Schneidekraft.
- Eingebaute Hartmetall-Picke für Mehrzweckanwendung
- Diseño X, fuerza de corte superior.
- Clip metálico duro integrado para las aplicaciones multiuso

**WHEEL-LOCK**

- VERROUILLAGE POSITIF PAR MOLETTE
- POSITIVE RADVERRIEGELUNG
- BLOQUEO POSITIVO A RUEDECILLA

**AUTO-LOCK**

- VERROUILLAGE AUTOMATIQUE
- AUTO-LOCK KLINGENFESTSTELLER
- BLOQUEO AUTOMATICO

**STAINLESS STEEL BLADE**

- LAME ACIER INOXIDABLE
- KLINGE AUS ROSTFREIEM
- CUCHILLA DE ACERO INOXIDABLE

**ACID AND ACETONE RESISTANT**

- RÉSISTANT À LACIDE ET À L'ACÉTONE
- SÄURE UND AZETON BESTÄNDIG
- RESISTENTE AL ÁCIDO Y A LA ACETONA

**ULTRA SHARP BLADE**

- LAME ULTRA AIGUISÉE
- ULTRA-SHARFE KLINGE
- CUCHILLA ULTRA AFILADA

**FOR BOTH RIGHT- AND LEFT- HANDED USERS**

- POUR UTILISATEURS GAUCHERS ET DROITIERS
- FÜR RECHTS- UND LINKSHÄNDER
- PARA USUARIOS DIESTROS Y ZURDOS

**BLADE WITH SINGLE SIDE SHARPENING**

- LAME AVEC UN SEUL CÔTÉ AFFÛTÉ
- EINSEITIG GESCHÄRFTE KLINGE
- CUCHILLA DE FILO ÚNICO

**PATENTED**

- BREVETÉ
- PATENTADO
- PATENTIERT

**PATENT PENDING**

- EN ATTENTE DE BREVET
- PATENTE PENDIENTE
- ANGEMELDETES PATENT

**PRODUCTS DESIGNED WITH SAFETY IN MIND.**

- DES PRODUITS CONÇUS AVEC LA SÉCURITÉ COMME PRIORITÉ.
- PRODUKTE, BEI DEREN ENTWICKLUNG DIE SICHERHEIT IM VORDERGRUND STAND.
- PRODUCTOS DISEÑADOS PENSANDO EN LA SEGURIDAD.

**HANDLE MADE FROM RECYCLED PLASTIC.**

- MANCHE COMPOSÉ À DE PLASTIQUE RECYCLÉS.
- HANDGEFERTIGT AUS RECYCELTEM MATERIAL.
- HECHO A MANO CON PLÁSTICO RECICLADO.

[www.certipedia.com](http://www.certipedia.com)

GS (Geprüfte Sicherheit) marked OLFA products are approved for "quality/safety" under German product safety laws. The GS mark is recognized as a safety certification not only in Germany but also in the rest of the world.

- Les produits de la marque GS (Gepüfte Sicherheit) sont approuvés par les normes allemandes de «Qualité/Sécurité».
- La marque GS est reconnue en tant que de conformité de référence non seulement en Allemagne mais aussi dans le reste du monde.
- Mit GS (Gepüfte Sicherheit) ausgezeichnete Produkte sind für „Qualität/Sicherheit“ unter deutschen Produktsicherheitsgesetzen anerkannt.
- Die GS-Kennzeichnung ist nicht nur in Deutschland als Sicherheitszertifikat bekannt, sondern auf der ganzen Welt.
- Los productos con la marca GS (Gepüfte Sicherheit) han sido aprobados por su "Calidad/Seguridad" según las leyes alemanas de seguridad en productos. La marca GS es reconocida como un certificado de seguridad no sólo en Alemania sino también en el resto del mundo.



NSF certification is a key to making sure that the products meet strict standards for public health protection. American National Standards Institute applies the NSF certifications.

- La certification NSF est essentielle pour s'assurer que les produits satisfont des normes strictes pour la protection de la santé publique.
- L'Institut national de normalisation américain applique les certifications NSF.
- Die NSF-Zertifizierung ist entscheidend, um sicherzustellen, dass die Produkte die strengen Standards für den Schutz der öffentlichen Gesundheit erfüllen. Das American National Standards Institute wendet die NSF-Zertifizierungen an.
- La certificación NSF es la clave para cerciorarse de que los productos cumplen los estrictos estándares para la protección de la salud pública.
- El Instituto de Estándares Nacionales Americanos aplica las certificaciones NSF.

**SPARE BLADE**

- LAMES DE RECHANGE
- ERSATZKLINGEN
- CUCHILLAS DE REPUESTO

**PACKAGING**

- EMBALLAGE
- VERPACKUNG
- EMBALAJE

**CARTON CONTENTS**

- CONTENU DE CARTON
- KARTONINHALF
- CONTENIDO DE EMBALAJE

**CONTENTS**

- SOMMAIRE
- INHALT
- TABLA DE CONTENIDO

**Extra Heavy-Duty Models**  
▶ P11**Heavy-Duty Models**  
▶ P12~18**Medium-Sized Models**  
▶ P19~20**Standard-Duty Models**  
▶ P21~24**Blade Disposal Cases**  
▶ P25**Scissors**  
▶ P26**Safety Models**  
▶ P27~30**Scrapers**  
▶ P31~33**Rotary Cutters ·  
Quilt Rulers**  
▶ P34~38**Other Purpose-  
Made Hand Tools**  
▶ P39~44**Cutting Mats**  
▶ P45~48**Custom Logo Printing  
Spare Blades**  
▶ P49~58

# Extra Heavy-Duty Models

25 mm

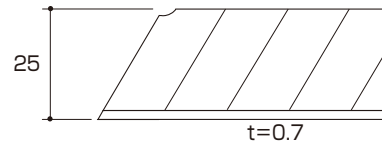

Featuring the 25mm blade, the extra heavy-duty cutters are most appropriate for professional work places.

## Modèles supplémentaires pour gros travaux

Avec la lame de 25 mm, les cutters supplémentaires pour les gros travaux sont plus appropriés pour les environnements de travail professionnels.

## Extra Stabile Modelle

Mit der 25-mm-Klinge sind die Cutter für schwere Arbeiten passend für professionelle Arbeitsplätze.

## Modelos de trabajo pesado extra

Con una cuchilla de 25 mm, los cortadores de uso industrial son más apropiados para entornos de trabajo profesionales.

Extra Heavy-Duty Models Heavy-Duty Models

### XH-1



X-Design, superior cutting force

- Conception-X, force de coupe supérieure
- X-Design, bessere Schneidekraft
- Diseño X, fuerza de corte superior



### XH-AL



X-Design, superior cutting force

- Conception-X, force de coupe supérieure
- X-Design, bessere Schneidekraft
- Diseño X, fuerza de corte superior



### NH-1



Anti-Slip Elastomer handle

- Poignée en élastomère antidérapante
- Rutschfester Elastomergriff
- Mango de elastómero antideslizante



### H-1



With large rubber cushion

- Avec un grand tampon en caoutchouc
- Mit großer Unterplatte
- Con almohadilla de caucho de gran tamaño



### HSW-1



Pre-loaded with a 25mm Saw blade

- Compact, avec une nouvelle lame scie de 25 mm
- Kompakt, mit einer neuen 25-mm-SÄGE-Klinge
- Compacta, con una nueva cuchilla SAW de 25 mm

The HSWB-1 blade delivers the ultimate combination of toughness and sharpness. Impulse Hardening Process improves blade's life. Electroless Nickel Plating on blade is for added durability and corrosion resistance.

- La lame HSWB-1 offre une association optimale de robustesse et d'affûtage. Le processus de durcissement par impulsion améliore la durée de vie de la lame. Le placage auto catalytique au nickel de la lame améliore la durabilité et la résistance à la corrosion.
- Die Klinge HSWB-1 bietet die ultimative Kombination aus Robustheit und Schärfe. Der Impulshärtungsprozess erhöht die Lebensdauer der Klinge. Die chemische Vernickelung auf der Klinge sorgt für zusätzliche Haltbarkeit und Korrosionsbeständigkeit.
- La cuchilla HSWB-1 ofrece la mejor combinación de rigidez y afilado. El proceso de endurecimiento por pulsos alarga la vida útil de la cuchilla. El chapado de níquel químico de la cuchilla proporciona una mayor durabilidad y resistencia a la corrosión.



# Heavy-Duty Models

Featuring the 18mm blade, the heavy-duty handles are best suited for versatile cutting works.

**18**  
mm



## Modèles pour gros travaux

Avec la lame de 18 mm, les poignées robustes sont particulièrement adaptées pour les travaux de coupe polyvalents.

## Stabile Modelle

Mit der 18-mm-Klinge sind die Griffe für schwere Arbeiten am besten für vielseitige Schneidarbeiten geeignet.

## Modelos de uso industrial

Con una cuchilla de 18 mm, las asas de uso industrial son las mejores para las tareas de corte versátiles.

**WOODY CUTTER**  
CUTTER WOODY / CORTADOR DE MADERA

Wood Pellets

WOOD 70% × PP 30%  
Wood Pellets (thinned wood)

UP TO 70%  
less plastic\*

Maintains grip even with greasy or sweaty hands

\*Biomass material uses up to 70% less plastic in the handle.

## WD-L/BRN



LBB/LB/LBD/  
LB-SOL/LFB/LWB



220×95×32 (mm)



6×20 (pcs.)

## WD-L/BRN/PX



LBB/LB/LBD/  
LB-SOL/LFB/LWB



190×44×30 (mm)



10×10 (pcs.)

Wood-Plastic composite handle made of approximately 70% wood mixed with plastic resin provides a firm grip even with oil on the hands.

- Le manche en matériau composite bois-plastique, composé d'environ 70 % de bois mélangé à de la résine plastique offre une bonne prise en main, même avec de l'huile sur les mains.
- Der Griff aus Holz-Kunststoff-Verbundwerkstoff, der zu ca. 70 % aus Holz und Kunststoff besteht, bietet auch mit Öl an den Händen einen festen Griff.
- El mango de compuesto de madera y plástico fabricado hecho de aproximadamente un 70% de madera mezclada con resina de plástico proporciona un agarre firme, incluso con aceite en las manos.



WD-L/BRN

WD-L/BRN/PX  
Paper Box Package



## WD-AL/BRN



LBB/LB/LBD/  
LB-SOL/LFB/LWB



220×95×32 (mm)



6×20 (pcs.)

## WD-AL/PX



LBB/LB/LBD/  
LB-SOL/LFB/LWB



190×44×30 (mm)



10×10 (pcs.)

Wood-Plastic composite handle made of approximately 70% wood mixed with plastic resin provides a firm grip even with oil on the hands.

- Le manche en matériau composite bois-plastique, composé d'environ 70 % de bois mélangé à de la résine plastique offre une bonne prise en main, même avec de l'huile sur les mains.
- Der Griff aus Holz-Kunststoff-Verbundwerkstoff, der zu ca. 70 % aus Holz und Kunststoff besteht, bietet auch mit Öl an den Händen einen festen Griff.
- El mango de compuesto de madera y plástico fabricado hecho de aproximadamente un 70% de madera mezclada con resina de plástico proporciona un agarre firme, incluso con aceite en las manos.



WD-AL/BRN

WD-AL/BRN/PX  
Paper Box Package



### MXP-L



LBB/LB/LBD/  
LB-SOL/LFB/LWB



220X95X29(mm)



6x10 (pcs.)

X-Design, superior cutting force.  
Solidly built aluminum die-cast body.  
The entire surface hardening makes the blade channel tough.  
Solidly built single-piece metal Wheel Lock.

- | Aluminium moulé sous pression. Corps moulé sous pression en aluminium solide. La conception globale du cutter rend le guide lame extrêmement robuste. Verrouillage de roue solidement construit en métal monobloc.
- | Griff aus Aluminium Druckguss. Solider Griff aus Aluminium Druckguss. Stabile und präzise Klingenführung im Aluminiumgriff. Robust gebautes, einteiliges Metallschloss.
- | Cuerpo de aluminio fundido. Cuerpo robusto fabricado en fundición de aluminio. Guía de la cuchilla de gran robustez debido al endurecimiento de toda la superficie. Cerradura de rueda metálica de una sola pieza de construcción sólida.



### MXP-AL



LBB/LB/LBD/LB-SOL/  
LFB/LWB



220X95X29(mm)



6x10 (pcs.)

X-Design, superior cutting force.  
Solidly built aluminum die-cast body.  
The entire surface hardening makes the blade channel tough.  
Slim auto-locking slider designed specifically for this model.

- | Aluminium moulé sous pression. Corps moulé sous pression en aluminium solide. La conception globale du cutter rend le guide lame extrêmement robuste. Glissière mince autobloquante spécifiquement conçue pour ce modèle.
- | Griff aus Aluminium Druckguss. Solider Griff aus Aluminium Druckguss. Stabile und präzise Klingenführung im Aluminiumgriff. Schlanker und automatisch schließender Schieber, der speziell für dieses Modell entwickelt wurde.
- | Cuerpo de aluminio fundido. Cuerpo robusto fabricado en fundición de aluminio. Guía de la cuchilla de gran robustez debido al endurecimiento de toda la superficie. Pulsador autobloqueante delgado diseñado específicamente para este modelo.



### L-5



LBB/LB/LBD/LB-SOL/  
LFB/LWB



220X95X25(mm)



6x20 (pcs.)

Built-in hard metal pick for multi-purpose applications

- | Conception-X, force de coupe supérieure. Pointe en métal dur intégrée pour applications polyvalentes
- | X-Design, bessere Schneidekraft. Eingebaute Hartmetall-Picke für Mehrzweckanwendung
- | Diseño X, fuerza de corte superior. Clip metálico duro integrado para las aplicaciones multiuso



### L5-AL



LBB/LB/LBD/LB-SOL/  
LFB/LWB



220X95X25(mm)



6x20 (pcs.)

Built-in hard metal pick for multi-purpose applications

- | Conception-X, force de coupe supérieure. Pointe en métal dur intégrée pour applications polyvalentes
- | X-Design, bessere Schneidekraft. Eingebaute Hartmetall-Picke für Mehrzweckanwendung
- | Diseño X, fuerza de corte superior. Clip metálico duro integrado para las aplicaciones multiuso



## L-7



LBB/LB/LBD/  
LB-SOL/LFB/LWB



220x95x28.4 (mm)



6x20 (pcs.)

X-design handles with a built-in lanyard hole. Best suited to use at overhead locations with a safety lanyard. Economical type.

- Les poignées de conception x sont fournies avec un passage de dragonne intégré. Optimisées pour une utilisation à des endroits en hauteur avec une lanterne de sécurité. Type économique.
- X-Design-Griffe verfügen über eine eingebaute Bandöse. Am besten geeignet für die Verwendung in Überkopfhaltungen mit einem Sicherheits-Halteband. Ökonomischer Typ.
- Las asas con diseño enxmanijas vienen con un orificio para cordón incorporado. Más adecuado para utilizar en ubicaciones por encima de la cabeza, con un cordón de seguridad. Tipo económico.



## L7-AL



LBB/LB/LBD/  
LB-SOL/LFB/LWB



220x95x26 (mm)



6x20 (pcs.)

X-design handles with a built-in lanyard hole. Best suited to use at overhead locations with a safety lanyard. Economical type.

- Les poignées de conception x sont fournies avec un passage de dragonne intégré. Optimisées pour une utilisation à des endroits en hauteur avec une lanterne de sécurité. Type économique.
- X-Design-Griffe verfügen über eine eingebaute Bandöse. Am besten geeignet für die Verwendung in Überkopfhaltungen mit einem Sicherheits-Halteband. Ökonomischer Typ.
- Las asas con diseño enxmanijas vienen con un orificio para cordón incorporado. Más adecuado para utilizar en ubicaciones por encima de la cabeza, con un cordón de seguridad. Tipo económico.

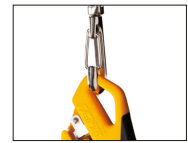

## L8-AL



LBB/LB/LBD/  
LB-SOL/LFB/LWB



220x95x28.5 (mm)



6x20 (pcs.)

The X-design handle is made of glassfiber-reinforced polypropylene and designed to help apply force without slipping. Featuring a unique shaped metal pick and Auto-Lock blade slider.

- Comprend un talon en métal de forme unique et un curseur de lame Auto-Lock.
- Mit einem einzigartig geformten Metallpickel und Auto-Lock-Klingenschieber.
- Cuenta con características únicas, una púa de metal y un deslizador de cuchilla con bloqueo automático



## KH-1/L5-AL



LBB/LB/LBD/LB-SOL/  
LFB/LWB



250x100x42 (mm)



6x10 (pcs.)

X-design Companion Holder (+ L5-AL) Locks your cutter securely in place, and you can release the lock with a natural squeezing motion. Large soft belt loop moves forward and backward by a maximum of 30 degrees. Package includes a L5-AL.

- Le KH-1 verrouille votre cutter X-design en toute sécurité et vous pouvez le déverrouiller d'une simple pression. L'emballage comprend un cutter L5-AL.
- Der KH-1 verriegelt Ihr X-design Messer sicher, und Sie können die Verriegelung auf einfache Weise lösen. Das Paket enthält einen L5-AL Cutter.
- El cortador KH-1 X design se bloquea de forma segura, y cuando quiera utilizar el cortador puede liberar el bloqueo con un movimiento de presión sencillo. El paquete incluye un cortador L5-AL.

# X-design Companion Holder (KH-1)

Made for the heavy-duty 18mm handles in OLFA's flagship X-design series





Quick Access!



L-1



LB/LBB/LBD/  
LB-SOL/LFB/LWB

220X80X24 (mm)

6X20 (pcs.)

L-1/green



LB/LBB/LBD/  
LB-SOL/LFB/LWB

220X80X24 (mm)

6X20 (pcs.)

Best and longest selling model

- Modèle le plus vendu depuis longtemps
- Das beste und am längsten verkaufte Modell
- El modelo de mayor y mejor venta

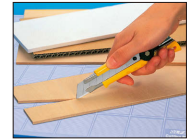

LTD-L-LFB



LFB/LB/LBB/LBD/  
LB-SOL/LWB

220X95X26.5 (mm)

6X10 (pcs.)

Pre-loaded with our high performance LFB blade for smooth and effortless cuts

- Pré-chargé avec une lame LFB à haute performance pour des coupes régulières et sans effort
- Enthält eine unserer leistungsstarken LFB-Klingen für glatte und mühelose Schnitte
- Pre cargado con nuestra cuchilla LFB de alto rendimiento para cortes suaves y sin esfuerzo



LTD-AL-LFB



LFB/LB/LBB/LBD/  
LB-SOL/LWB

220X95X24.5 (mm)

6X10 (pcs.)

Pre-loaded with our high performance LFB blade for smooth and effortless cuts

- Pré-chargé avec une lame LFB à haute performance pour des coupes régulières et sans effort
- Enthält eine unserer leistungsstarken LFB-Klingen für glatte und mühelose Schnitte
- Pre cargado con nuestra cuchilla LFB de alto rendimiento para cortes suaves y sin esfuerzo



SPEED BLADE®

LFB-5B

The "Speed Blade" cuts 2 times as fast through cardboard!

Fluorine-coated cutting surface. The fluorine coated surface reduces cut resistance drastically while cutting through cardboard.

- Surface de coupe revêtue de fluorose. La surface en fluorose revêtu réduit la résistance de coupe de manière drastique pendant la coupe d'un carton.
- Fluorbeschichtete Schneidfläche. Die fluoridbeschichtete Oberfläche reduziert den Schneidewiderstand beim Schneiden durch einen Karton drastisch.
- Superficie de corte revestida con flúor. La superficie recubierta por fluorosis reduce la resistencia al corte drásticamente al cortar cartón.

CUT RESISTANCE 50% compared to the LBB



## L-2



LB/LBB/LBD/  
LB-SOL/LFB/LWB



220×80×28.3 (mm)



6×20 (pcs.)

With large rubber cushion

- | Avec un large tampon en caoutchouc
- | Mit großer Unterplatte
- | Con almohadilla de caucho de gran tamaño



## BN-L



LB/LBB/LBD/  
LB-SOL/LFB/LWB



220×80×25.4 (mm)



6×20 (pcs.)

Versatile model in ergonomic design

- | Modèle polyvalent à la conception ergonomique
- | Vielfältiges Modell im ergonomischen Design
- | Modelo versátil de diseño ergonómico



## BN-AL



LB/LBB/LBD/  
LB-SOL/LFB/LWB



220×80×25 (mm)



6×20 (pcs.)

Versatile model in ergonomic design

- | Modèle polyvalent à la conception ergonomique
- | Vielfältiges Modell im ergonomischen Design
- | Modelo versátil de diseño ergonómico



## DL-1



PAT.



LB/LBB/LBD/LFB



220×95×24 (mm)



6×20 (pcs.)

With detachable blade snapper/disposal case

- | Avec casse-lame/boîte de lames usagées
- | Mit Klingenschnapper/Entsorgungsbehälter
- | Con desglosador de cuchillas/ estuche para descarte



**PL-1**



LBx3



LB/LBB/LBD/  
LB-SOL/LFB/LWB



222x113x27 (mm)



6x20 (pcs.)

Auto-loading up to 6 blades

- | Chargement automatique jusqu'à 6 lames
- | Automatisches Laden mit bis zu 6 Klingen
- | Carga automática de hasta 6 cuchillas

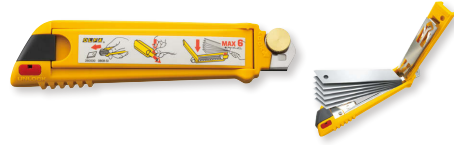

**SL-1**



LB/LBB/LBD/  
LB-SOL/LFB/LWB



220x80x19 (mm)



6x20 (pcs.)

With unique tractor locking system

- | Avec un système de verrouillage unique
- | Mit einzigartigem Verschlussystem
- | Con sistema de bloqueo único

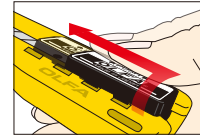

To slide

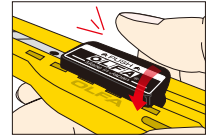

To lock

**EXL**



LB/LBB/LBD/  
LB-SOL/LFB/LWB



220x80x27 (mm)



6x20 (pcs.)

High cost-performance model

- | Modèle d'un excellent rapport qualité-prix
- | Preis-Leistungs-Modell
- | Modelo de alto rendimiento



**ML**



LB/LBB/LBD/  
LB-SOL/LFB/LWB



220x80x16.5 (mm)



6x20 (pcs.)

With metal handle

- | Avec poignée en métal
- | Mit Metallgriff
- | Con mango metálico



## OL



LB/LBB/LBD/  
LB-SOL/LFB/LWB

220X95X23.2 (mm)

6X20 (pcs.)

With extended blade channel & steel tucker

- Avec conduit de lame prolongé et corps en acier
- Mit erweitertem Klingenkanal & Stahl-Falzmesser
- Con canal para cuchilla amplio y paleta de acero

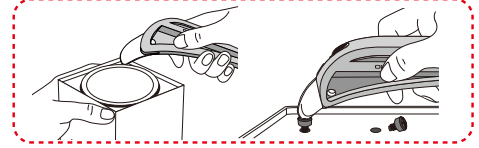

## XL-2



LB/LBB/LBD/  
LB-SOL/LFB/LWB

355X75X26.6 (mm)

6X10 (pcs.)

For jobs requiring extra reach

- Pour des travaux nécessitant une grande flexibilité
- Für Arbeiten mit einem größeren Wirkungsbereich
- Para aquellos trabajos que requieran de mayor alcance



## CMP-2



LB/LBB/LBD/LFB

240X116X42 (mm)

5X10 (pcs.)

Circle cutter for diameter 7-30cm

- Cutter circulaire pour diamètre de 7 à 30 cm
- Kreismesser für Durchmesser. 7-30 cm
- Cortador circular para diámetros de 7 a 30 cm

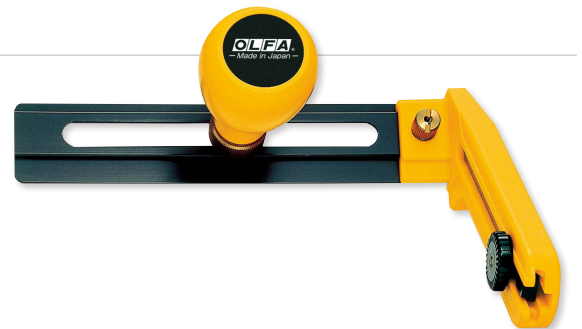

## INSULATION BLADE LWB-3B

Smoothly cuts slippery materials with wave-shaped edge.

Serrated blade firmly grips slippery materials. The solid serrated blade outperforms the LB blade when cutting thick elastic materials such as thermal insulations, pipe covering materials and ropes.

Lame dentelée qui serre fermement même les matériaux glissants. La lame dentelée solide surpasse la lame LB pendant la coupe de matériaux élastiques épais tels que les isolants thermiques, couvrant les matériaux pour la tuyauterie et les cordes.

Gezähnte Klinge, die selbst rutschige Materialien fest greift. Die stabile gezähnte Klinge übertrifft die LB-Klinge beim Schneiden dicker elastischer Materialien wie Thermoisolationen, Abdeckmaterialien für Rohre und Seilen.

Cuchilla serrada que fija firmemente hasta los materiales deslizantes. La sólida cuchilla dentada supera el rendimiento de la cuchilla LB cuando se cortan materiales elásticos gruesos, como por ejemplo aislamientos térmicos, cubriendo materiales para tuberías y cuerdas.

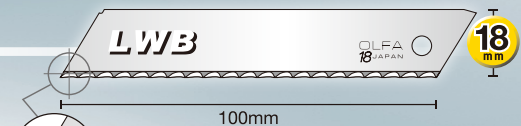

### Waved Edge

Best suited for cutting thermal insulations, covering materials for piping, roofing materials and ropes. The wave-shaped edge cuts slippery hard-to-cut materials. The solid blade, without segment lines, allows users a dynamic cutting, using the whole knife edge.

0.5mm

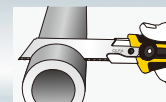

Vinyl coated pipe covering



Ropes



Glass wool

# Medium-Sized Models 12.5 mm

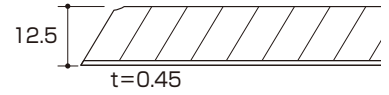

- | Modèles médium
- | Medium Modelle
- | Modelos medianos

Medium-Sized Models

## COMPACT but TOUGH 12.5mm model

More compact and lightweight than the 18mm with enough toughness in blade.

The 0.45mm-thick 12.5mm MTB blade bridges the gap between the 9mm blade and the 18mm blade.

- La lame de 0.45mm d'épaisseur 12.5mm MTB est intermédiaire entre la lame de 9mm et la lame de 18mm.
- Die 0.45mm dicke 12.5-mm-MTB-Klinge schließt die Lücke zwischen der 9-mm-Klinge und der 18-mm-Klinge.
- La cuchilla MTB de 0.45mm de grosor y de 12.5mm acorta la distancia entre la cuchilla de 9mm y la de 18mm.

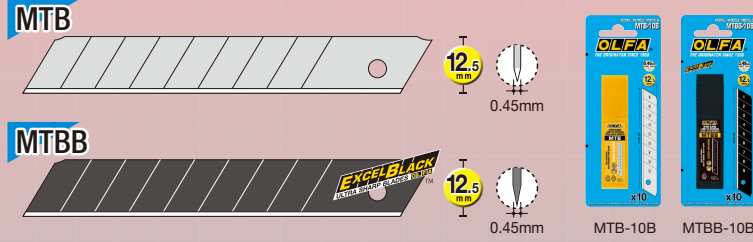

### XMT-1



X-design handle with Auto-Lock. Its sure grip made of elastomer and glass-fiber-reinforced polypropylene is chemically resistant to paint. Built-in metal pick opens paint cans.

- | Une lame plus résistante dans un format compact avec notre poignée X-Design pour une meilleure stabilité.
- | Eine robuste Klinge in kompakter Größe mit unserem X-Design-Griff für zusätzliche Stabilität.
- | Una cuchilla resistente de un tamaño compacto con nuestro agarre X-Design para mayor estabilidad.



### MT-1



The most versatile cutter

- | Le cutter le plus polyvalent
- | Das vielseitigste Messer
- | El cortador más versátil



## CS-5



MTB/MTBB/SWB-5



228X92X33.8 (mm)



6X10 (pcs.)

A combination of Keyhole Saw and 12.5mm Snap-Off Blade Cutter. 2 blades in 1 handle, ideal for electricians.

- Une combinaison de scie à oïlet et de lame de cutter détachables de 12.5 mm. 2 lames dans 1 poignée pour les electriciens.
- Eine Kombination von Stichsäge und 12.5-mm-Cutter mit Abknick-Klinge. 2 Klingen in 1 Griff für Elektriker.
- Una combinación de sierra tipo cerradura y un cortador con cuchilla desglósable de 12.5 mm. 2 cuchillas en 1 asa para electricistas.



### The bi-directional saw blade cuts while pushing and pulling, leaving a clean cut surface.

- La lame de scie bidirectionnelle coupe lorsqu'elle est retirée mais aussi lorsqu'elle est poussée, en laissant une surface de coupe propre.
- Das bidirektionale Sägeblatt schneidet beim Ziehen und ebenfalls beim Drücken und hinterlässt eine saubere Schnittoberfläche.
- La cuchilla de sierra bidireccional corta al tirarle ella y también al empujarla, dejando una superficie de corte limpia.

#### SWB-5 1.25mm-thick pointed saw blade

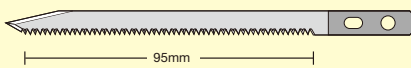

Sharp-pointed tip drills a hole in a board to start cutting.

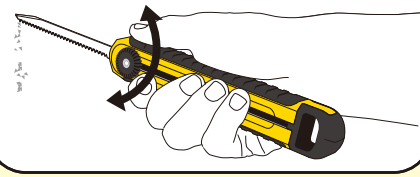

SWB-5/1B

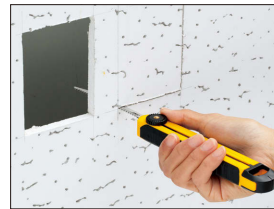

## Professional Wallpaper Cutter

- Cutter Spécial Papier Peint
- Profii-Tapetenmesser
- Cortador Profesional para Tapizado de Paredes

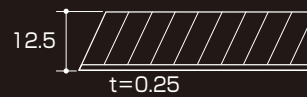

For **Wallpaper**

### FWP-1



FWB



220X80X16 (mm)



6X40 (pcs.)

Thinner blade ideal for cutting wallpaper

- Cutter à lame plus fine pour revêtement mural
- Dünneres Klingen-Wandverkleidungsmesser
- Cortador fino con cuchilla para revestimiento de pared

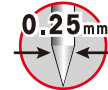

### The 0.25mm-thin Ultra Sharp Black Blade leaves a beautiful cut surface.

- La lame noire affûtée ultra épaisse de 0.25 mm laisse une belle surface de coupe.
- Die dünne 0.25 mm dicke Ultra Sharp Black-Klinge hinterlässt eine wunderschöne Schnittoberfläche.
- La cuchilla Ultra Sharp Black fina de 0.25 mm de grosor deja una bonita superficie de corte.

#### FWB



FWB-10

For **Wallpaper**



# Standard-Duty Models

Featuring the 9mm blade, standard-duty cutters are best-suited for precise cutting needs as well as general purposes.

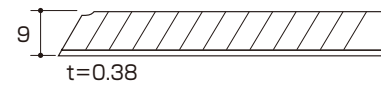

## Modèles standards

Avec la lame de 9 mm, les cutters standards sont mieux adaptés pour assurer la précision de coupe ainsi que des utilisations générales.

## Standard Modelle

Mit der 9-mm-Klinge sind Cutter für Standardarbeiten besser geeignet für präzise Schneidearbeiten sowie für allgemeine Aufgaben.

## Modelos estándar

Con una cuchilla de 9 mm, los cortadores para tareas estándar son más adecuados para trabajos de corte precisión así como para fines generales.

### XA-1



The X-design handle in a convenient and compact size

- La poignée de conception en X est pratique et compacte
- Griff im X-Design in einer bequemen und kompakten Größe
- Mango de diseño en X en un tamaño cómodo y compacto

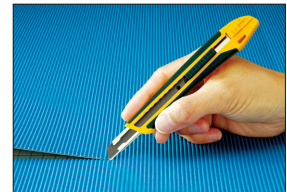
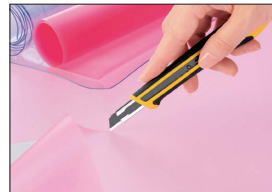

### A-1



Evolutional Classic A, with blade snapper/clip

- Evolutional Classic A, avec casse-lame/clip
- Evolutionär Klassik A, mit Klingenschnapper/Clip
- Clásico evolutivo A con partidor/clip de cuchilla

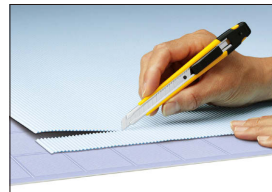

### SAC-1



With 30-degree angle blade

- Avec lame d'angle à 30 degrés
- Mit 30 Grad Winkelklinge
- Con cuchilla en ángulo de 30 grados

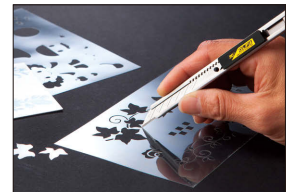

### A-5



With original one-way locking system

- Avec système de verrouillage à sens unique
- Mit einseitigem Verriegelungssystem
- Con sistema de bloqueo unidireccional

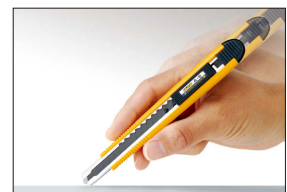

## SVR-1

### STAINLESS STEEL BLADE AB-Sx3

 AB-S/AB/ABB/AB-SOL  220x80x17.4 (mm)  6x40 (pcs.)

Stainless steel model

- | Tous les modèles en acier inoxydable
- | Modell komplett aus Edelstahl
- | Todos los modelos son de acero inoxidable



## SVR-2

### AUTO LOCK STAINLESS STEEL BLADE AB-Sx3

 AB-S/AB/ABB/AB-SOL  220x80x12.1 (mm)  6x40 (pcs.)

Stainless steel model

- | Tous les modèles en acier inoxydable
- | Modell komplett aus Edelstahl
- | Todos los modelos son de acero inoxidable

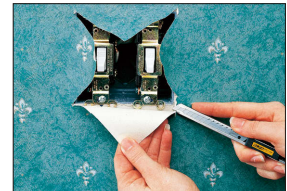

## A-2

 AB/ABB/AB-S/AB-SOL  220x80x13.5 (mm)  6x40 (pcs.)

Basic model with rubber grip

- | Modèle de base avec poignée en caoutchouc
- | Grundmodell mit Gummigriff
- | Modelo básico con mango de caucho



## DA-1

### AUTO LOCK AB/ABB/AB-S

 AB/ABB/AB-S  220x80x19 (mm)  6x40 (pcs.)

With detachable blade snapper/disposal case

- | Avec casse-lame/boîte de lames usagées
- | Mit Klingenschnapper/Entsorgungsbehälter
- | Con desglosador de cuchillas/ estuche para descarte



**PA-2**



**ABBx2**



ABB/AB/AB-S/AB-SOL



220x80x16 (mm)



6x40 (pcs.)

Auto-loading up to 5 blades

- | Chargement automatique jusqu'à 5 lames
- | Automatisches Laden mit bis zu 5 Klingen
- | Carga automática de hasta 5 cuchillas

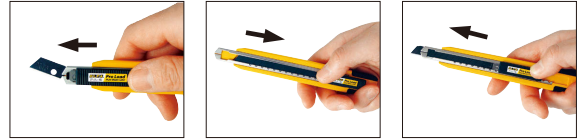

**300**



AB/ABB/AB-S/AB-SOL



220x80x17.8 (mm)



6x20 (pcs.)

With screw locking system

- | Avec un système de verrouillage par vissage
- | Mit Schraubverschlussystem
- | Con sistema de bloqueo por tornillo

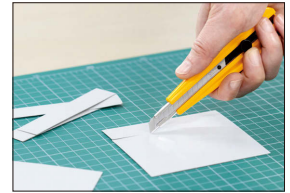

**A-3**



AB/ABB/AB-S



220x80x12.2 (mm)



6x40 (pcs.)

Two-way cutter

- | Cutter double-sens
- | Zweiseitiges Messer
- | Cuchilla bidireccional

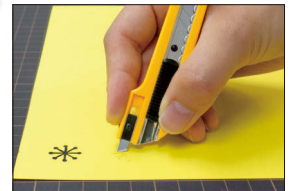

## SPC-1/40



AB/ABB/AB-S/AB-SOL



170x106x103 (mm)



40x20 (pcs.)

High cost-performance model

- | Modèle d'un excellent rapport qualité-prix
- | Preis-Leistungs-Modell
- | Modelo de alto rendimiento

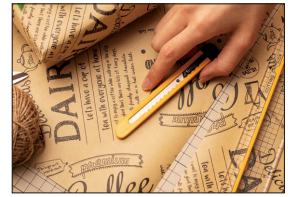

## ES-1/green



AB/ABB/AB-S/AB-SOL



220x80x17.6 (mm)



6x40 (pcs.)

Able to disassemble into 5 parts for recycling

- | Permet de démonter en 5 parties pour le recyclage
- | Kann zum Recyceln in 5 Teile auseinandergenommen werden
- | Permite su desmantelamiento en 5 partes para su reciclaje

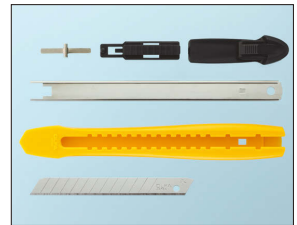

## S



AB/ABB/AB-S/AB-SOL



220x50x10.6 (mm)



6x80 (pcs.)



S

## S/20



AB/ABB/AB-S/AB-SOL



357x244x10 (mm)



20x30 (pcs.)

Slim metal body with blade snapper/clip

- | Corps en métal allégé avec casse-lame/clip
- | Schlanker Metallkörper mit Klingenschnapper/Clip
- | Cuerpo metálico fino con desglosador de cuchilla/clip



S



S/20

## 180 Black



AB/ABB/AB-S/AB-SOL



220x80x11.9 (mm)



6x40 (pcs.)



180 Black

## 180-BT/36



AB/ABB/AB-S/AB-SOL



248x145x163 (mm)



36x10 (pcs.)

Metal handle with blade snapper/clip

- | Poignée métallique avec casse-lame/clip
- | Metallgriff mit Klingenschnapper/Clip
- | Mango metálico con desglosador de cuchillas/clip



180-BT/36



# Blade Disposal Cases



Keeping the blade edge sharp all the time leads to safety. OLFA Blade Disposal Cases help users snap off a blade and store used blade segments safely until disposing of them.



## Boîte de lames usagées.

Garder le bord de la lame constamment affûté entraîne la sécurité. Les boîtes de lames usagées OLFA aident les utilisateurs à casser une lame et à ranger en toute sécurité des morceaux de lame usées jusqu'au rebut de ces derniers.

## Entsorgungsbehälter

Das ständige Scharfhalten der Klingenschneide führt zu mehr Sicherheit. OLFA Klingen-Entsorgungsbehälter helfen Verwendern, eine Klinge abzubrechen und gebrauchte Klingensegmente sicher aufzubewahren, bis sie entsorgt werden.

## Estuche para descarte.

Mantener el filo afilado todo el tiempo para aumentar la seguridad. Los estuches para el desecho de cuchillas OLFA ayuda a los usuarios a desglosar una cuchilla y almacenar los segmentos usados de la cuchilla de forma segura hasta que se deshaga de ellos.

### DC-3



269×70×67 (mm)



10×20(pcs.)

### DC-4



148×72×29 (mm)



6×20(pcs.)



**For safety, the environment & convenience.  
For getting a fresh cutting point comfortably & safely.**

Par mesure de sécurité, pour des raisons environnementales et de convenance. Pour obtenir confortablement et en toute sécurité des points de coupe nets.

Für Sicherheit, Umwelt & Komfort. Für das bequeme & sichere Erlangen eines frischen Schneidepunktes.

Por motivos de seguridad, medioambiente y conveniencia. Para obtener un punto de corte preciso, confortable y seguro.

### DC-5



220×100×40 (mm)



6×20(pcs.)

Blade Disposal Holster

- Etui pour lames usagées
- Klingensorgungshalterung
- Portador de hojas desechables



※The DC-5 is NOT compatible with: All the 25mm extra heavy-duty models, 18mm heavy-duty models: CL, PL-1, SL-1, CMP-2, and 9mm standard-duty models: PA-2, SPC-1, ES-1/green.

※Le DC-5 n'est PAS compatible avec : Tous les modèles supplémentaires pour gros travaux de 25 mm, modèles de 18 mm pour gros travaux : CL, PL-1, SL-1, CMP-2 et les modèles standard de 9 mm : PA-2, SPC-1, ES-1/vert.

※Das DC-5 ist NICHT kompatibel mit: Allen 25-mm-Modellen für extra schwere Arbeiten, 18-mm-Modellen für schwere Arbeiten: CL, PL-1, SL-1, CMP-2 und 9-mm-Modellen für Standardarbeiten: PA-2, SPC-1, ES-1/grün.

※El DC-5 NO es compatible con: Todos los modelos de uso industrial extra de 25 mm, modelos de uso industrial de 18 mm: CL, PL-1, SL-1, CMP-2 y los modelos de uso estándar de 9 mm: PA-2, SPC-1, ES-1/verde.

### DC-6



200×100×83 (mm)



5×10(pcs.)

Complete Desktop Blade Disposal system

- Solution complete de bureau pour rangement de lames.
- Komplettes arbeitsoberflächenklingensorgungssystem.
- Sistema completo de desecho de cuchillas para escritorios.



※The DC-6 is NOT compatible with: All the 25mm extra heavy-duty models, 18mm heavy-duty models: CL, OL, PL-1, SL-1, CMP-2, ML, and 9mm standard-duty models: PA-2, SPC-1, ES-1/green.

※Le DC-6 n'est PAS compatible avec : Tous les modèles supplémentaires pour les gros travaux de 25 mm, modèles pour gros travaux de 18 mm : CL, OL, PL-1, SL-1, CMP-2, ML et les modèles standard de 9 mm : PA-2, SPC-1, ES-1/vert.

※Das DC-6 ist NICHT kompatibel mit: Allen 25-mm-Modellen für extra schwere Arbeiten, 18-mm-Modellen für schwere Arbeiten: CL, OL, PL-1, SL-1, CMP-2, ML und 9 mm Modellen für Standardarbeiten: PA-2, SPC-1, ES-1/grün.

※El DC-6 NO es compatible con: Todos los modelos de uso industrial extra de 25 mm, modelos de uso industrial de 18 mm: CL, OL, PL-1, SL-1, CMP-2, ML y modelos de uso estándar de 9 mm: PA-2, SPC-1, ES-1/verde.

## DC-7



163×45×32 (mm)



6×20 (pcs.)

Designed for professional use and perfectly sized to fit in a waist bag/bag pocket. With the easy-to-insert arched blade snapping slit, the blade can be snapped off smoothly and freely. By sliding down the blade along the slope, the blade can be inserted safely. It safely stores used blade segments, enhancing safety and efficiency on workplaces. The main body is acetone resistant.

\*The DC-7 is NOT compatible with: All the 25mm extra heavy-duty models, and 18mm heavy-duty models: OL, CMP-2, XL-2.

Conçu pour un usage professionnel et parfaitement dimensionné pour tenir dans un sac accroché à la taille ou dans une poche de sac. Grâce à la fente d'insertion facile d'usage, la lame peut être extraite en toute simplicité. \*La DC-7 n'est PAS compatible avec : Tous les modèles supplémentaires pour les gros travaux de 25 mm, et les modèles pour gros travaux de 18 mm : OL, CMP-2, XL-2.

Konzipiert für den professionellen Einsatz. Bietet die perfekte Größe für die Tragetaschen. Die Klinge lässt sich einfach, problemlos und frei abschneiden. \*Das DC-7 ist NICHT kompatibel mit: Allen 25-mm-Modellen für extra schwere Arbeiten, und 18-mm-Modellen für schwere Arbeiten: OL, CMP-2, XL-2.

Diseñado para uso profesional con el tamaño perfecto para guardar en una riñonera o bolsillo. Gracias a la hendidura arqueada, la cuchilla se puede quitar fácil y suavemente. \*El DC-7 NO es compatible con: Todos los modelos de uso industrial extra de 25 mm, y los modelos de uso industrial de 18 mm: OL, CMP-2, XL-2.

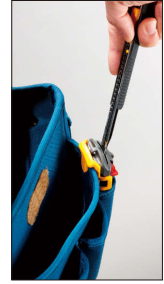

DC-7 Paper Box Package

# Scissors

OLFA scissors with a straight edge or with a serrated edge for versatile work.

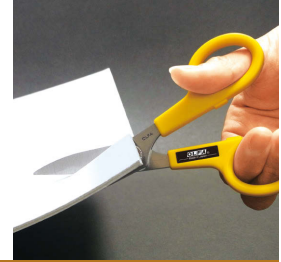

### Ciseaux

Ciseaux OLFA avec lame plate, avec lame dentée pour le travail polyvalent.

### Scheren

OLFA Scheren mit gerader Schneide, mit gezahnter Schneide für vielseitige Arbeiten.

### Tijeras

Las tijeras OLFA con filo recto, con filo en sierra para trabajo versátil.

## SCS-1



220×95×9.7 (mm)



6×20 (pcs.)

Tough serrated scissors, Small

Ciseaux dentés résistants, petit modèle

Grob gezackte Scheren, Klein

Tijeras dentadas resistentes, Pequeñas

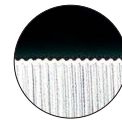

(Blade enlarged view)



## SCS-2



220×105×13.5 (mm)



6×20 (pcs.)

Tough serrated scissors, Large

Ciseaux dentés résistants, grand modèle

Grob gezackte Scheren, Groß

Tijeras dentadas resistentes, Grandes

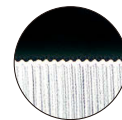

(Blade enlarged view)

## SCS-4



220×95×10 (mm)



6×20 (pcs.)

For more precise work

Pour un travail plus précis

Für genaueres Arbeiten

Para un trabajo más preciso



(Blade enlarged view)



# Safety Models



Every OLFA Safety Knife makes a contribution to safe working conditions.



## Modèles de sécurité

Chaque couteau de sécurité OLFA contribue à des conditions de travail en toute sécurité.

## Sicherheits-Modelle

Liefert jedes OLFA Sicherheitsmesser einen Beitrag zu sicheren Arbeitsbedingungen.

## Modelos de seguridad

Cada cuchillo de seguridad OLFA contribuye a unas condiciones de trabajo seguras.

Safety Models

### SEMI AUTO RETRACT - Blade will automatically retract if slider is released.

- RETRACTION SEMI AUTO - La lame se rétracte automatiquement lorsque le curseur est relâché.
- HALBAUTOMATISCHER RÜCKZUG - Die Klinge wird automatisch zurückgezogen, wenn der Schieber losgelassen wird.
- RETROCESO SEMIAUTOMÁTICO - La cuchilla se retrae automáticamente si se suelta el pulsador.

## SK-4



SKB-2/SKB-2S/SKB-2S-R/  
RSKB-2/HOB-2

220×80×25.1 (mm)

6×20 (pcs.)



SK-4

## SK-4/green



SKB-2/SKB-2S/SKB-2S-R/  
RSKB-2/HOB-2

220×80×26 (mm)

6×20 (pcs.)



SK-4/green

The best selling safety cutter

- Le cutter de sécurité le plus vendu
- Das meistverkaufte Sicherheitsmesser
- El cortador de seguridad más vendido

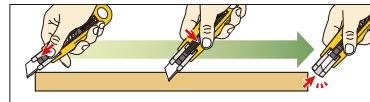

## SK-4/24



SKB-2/SKB-2S/SKB-2S-R/  
RSKB-2/HOB-2

257×170×139 (mm)

24×6 (pcs.)



Cost-saving bulk package

- Emballage en vrac pour des économies de coûts
- Kostengünstige Großpackung
- Paquete a granel económico

## SK-4/HOK



HOB-2/SKB-2/SKB-2S/  
SKB-2S-R/RSKB-2/

220×80×23 (mm)

6×20 (pcs.)



The long selling safety cutter SK-4, pre-loaded with a HOB-2 hook blade

- Longue lame de sécurité SK-4, préchargée avec une lame à crochet HOB-2
- Der beliebte Sicherheitscutter SK-4 kommt mit einer HOB-2-Hakenklinge
- Una cuchilla resistente de un tamaño compacto con nuestro agarre X-Design para mayor estabilidad

## SK-5



SKB-2/SKB-2S/SKB-2S-R/  
RSKB-2/HOB-2

220×80×22.4 (mm)

6×20 (pcs.)



Anti-Slip Elastomer handle

- Poignée en élastomère antidérapante
- Rutschfester Elastomergriff
- Mango de elastómero antideslizante

## SK-7



## SK-7/green



Compact safety cutter

- Cutter de sécurité compact
- Kompaktes Sicherheitsmesser
- Cortador de seguridad compacto

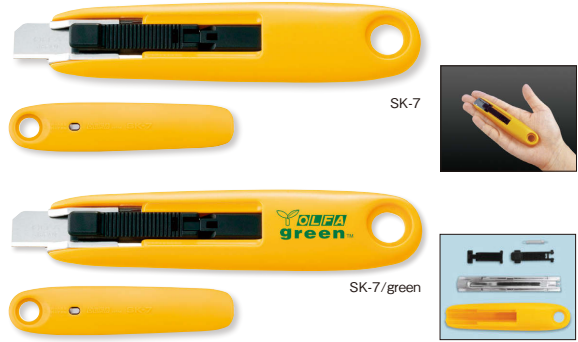

## SK-7/24



Cost-saving bulk package

- Emballage en vrac pour des économies de coûts
- Kostengünstige Großpackung
- Paquete a granel económico



## SK-9



With metal tape slitter

- Avec découpeuse à ruban métallique
- Mit Metall-Bandlängsschneider
- Con cortador de cinta de metal



## SK-9/32



Cost-saving bulk package

- Emballage en vrac pour des économies de coûts
- Kostengünstige Großpackung
- Paquete a granel económico



## SK-12



All stainless steel self-retracting knife. NSF-certified cleanability.  
 ※The SK-12 is NOT designed for cutting food itself.

- Cutter "sécurité", lame inox auto rétractable. Lavabilité certifiée NSF.  
 ※Le SK-12 n'est PAS conçu pour découper des aliments.
- Sicherheitsmesser aus Edelstahl. NSF-zertifizierte Waschbarkeit.  
 ※Das SK-12 ist NICHT zum Schneiden von Lebensmitteln gedacht.
- Cutter de seguridad auto retráctil 100% inoxidable. Lavabilidad con certificación NSF.  
 ※SK-12 NO ha sido diseñado para cortar alimentos.



## SK-12/24



Cost-saving bulk package

- Emballage en vrac pour des économies de coûts
- Kostengünstige Großpackung
- Paquete a granel económico



**FULL AUTO RETRACT - Blade retracts automatically after cutting.**

- | RÉTRACTION AUTOMATIQUE TOTALE - La lame se rétracte automatiquement après la coupe.
- | VOLLSTÄNDIGER AUTOMATISCHER RÜCKZUG - Klinge wird nach dem Schneiden automatisch zurückgezogen.
- | RETRACCIÓN AUTOMÁTICA COMPLETA - La cuchilla se retrae automáticamente después del corte.

**SK-6**



RSKB-2



220X95X20 (mm)



6X12 (pcs.)

Automatic protection guard

- | Carter de protection automatique
- | Automatische Schutz Einrichtung
- | Cubierta de protección automática



**SK-8**



SKB-8



220X95X24.1 (mm)



6X20 (pcs.)

Automatic self-retracting system

- | Système auto-rétractable automatique
- | Automatisches selbst einziehendes System
- | Sistema auto-retráctil automático

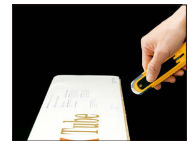

**SK-8/24**



SKB-8

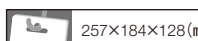

257X184X128 (mm)



24X6 (pcs.)

Cost-saving bulk package

- | Emballage en vrac pour des économies de coûts
- | Kostengünstige Großpackung
- | Paquete a granel económico



## CONCEALED BLADE - Minimal blade exposure, maximum productivity.

- | LAME DISSIMULEE- Exposition minimale de la lame, productivité maximale.
- | GESCHÜTZTE KLINGE – geschützte Klinge minimiert das Verletzungsrisiko.
- | CUCHILLA OCULTA - Exposición mínima de la cuchilla, máxima productividad.

### SK-10



SKB-10



220X95X13 (mm)



6X20 (pcs.)

Stretch Wrap Cutter

- | Cutter extensible pour emballage
- | Streckverpackungs messer
- | Cutter para flejes y films



### SK-10/24



SKB-10



234X212X86 (mm)



24X8 (pcs.)

Cost-saving bulk package

- | Emballage en vrac pour des économies de coûts
- | Kostengünstige Großpackung
- | Paquete a granel económico



### SK-15/10

### SK-15/10/BLU

### SK-15/10/WHT



190X120X14 (mm)



100X6 (pcs.)

Concealed blade cutter with built-in tape splitter for all your unpacking needs.

- | Cutter avec massicot intégré pour tous vos besoins de déballage.
- | Cutter mit einziehbarer Klinge und eingebautem Klebebandschneider für alle Auspackbedürfnisse.
- | Cortador de cuchilla oculta con cortador de cinta integrado para todas las necesidades de desembalaje.



SK-15/10

SK-15/10/BLU

SK-15/10/WHT



### SK-15/DSB



232X131X97 (mm)



60X10 (pcs.)



### SK-16



SKB-16



220X95X21 (mm)



6X20 (pcs.)

Ideal for unpacking, cutting cardboard, carpet, and even heavy-duty flooring materials.

- | Idéal pour le déballage, la découpe de carton, de moquette et même des revêtements de sol robustes.
- | Ideal zum Auspacken, Schneiden von Karton, Teppich und sogar schweren Bodenbelägen.
- | Ideal para desembalar, cortar cartón, moqueta y materiales pesados para suelos.



# Scrapers

From handy type to heavy duty type, OLFA scrapers accommodate removing, scraping and cutting works.



## Grattoirs

De type à portée de main à type robuste, les racleurs OLFA s'adaptent au retrait, au raclement et aux travaux de coupe.

## Schabmesser

Vom praktischen Typ bis zum Typ für schwere Arbeiten, OLFA Schaber decken Arbeiten wie Entfernen, Schaben und Schneiden ab.

## Raspadores

Desde tipo práctico a tipo de uso industrial, los raspadores OLFA acomodan las tareas de extracción, raspado y corte.

The professional XSR Scraper Series feature a hammerable grip end and a heavy-duty 0.8mm-thick blade as standard equipment.

- La série de racleur XSR professionnel offre une extrémité de poignée de martelable et une lame épaisse robuste 0,8 mm comme équipement standard.
- Die professionelle XSR Schaberserie hat ein hämmerbares Griffende und eine 0,8 mm dicke Klinge für schwere Arbeiten als Standardausrüstung.
- La serie de raspadores profesionales XSR ofrecen una toma en el extremo que se puede utilizar con un martillo y una cuchilla de uso industrial de 0,8 mm de grosor como equipo estándar.

### XSR-200



ONE-SIDED SHARPENING



BS08/BS/BSF/LB



270X145X25 (mm)



5x6 (pcs.)

Scraper with 200mm-long X-design handle

- Racleur avec poignée de conception longue de 200 mm
- Schaber mit 200 mm langem X-Design Griff
- Rascador con un mango con diseño de una longitud de 200 mm



### XSR-300



ONE-SIDED SHARPENING



BS08/BS/BSF/LB



350X145X25 (mm)



5x6 (pcs.)

Scraper with 300mm-long X-design handle

- Racleur avec poignée de conception longue de 300 mm
- Schaber mit 300 mm langem X-Design Griff
- Rascador con un mango con diseño de una longitud de 300 mm



### XSR-600



ONE-SIDED SHARPENING



BS08/BS/BSF/LB



655X145X25 (mm)



5x6 (pcs.)

Scraper with 600mm-long X-design handle

- Racleur avec poignée de conception longue de 600 mm
- Schaber mit 600 mm langem X-Design Griff
- Rascador con un mango con diseño de una longitud de 600 mm

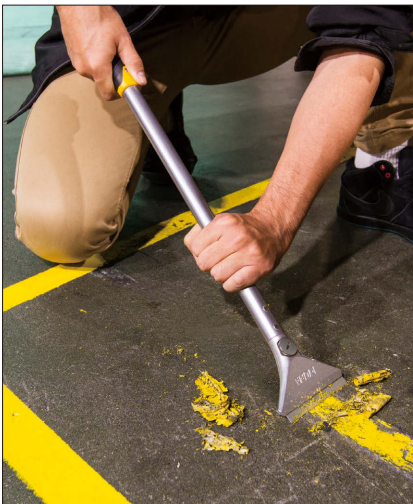

Suitable for glass surfaces. Excellent resistance to solvents. Tough against rust, too. Can be used in plumbing work. All metal parts made of stainless steel. Blade and handle of the same width. Can be used for working in corners and cramped openings.

Convient aux surfaces en verre. Excellente résistance aux solvants. Résiste efficacement à la rouille, aussi. Peut être utilisé dans les travaux de plomberie. Toutes les pièces métalliques sont en acier inoxydable. Lame et poignée de la même largeur. Peut être utilisé pour travailler dans les coins et dans des ouvertures restreintes.

Geeignet für Glasflächen. Ausgezeichnete Lösungsmittelbeständigkeit. Auch stark gegen Rost. Kann für Klempnerarbeiten verwendet werden. Alle Metallteile sind aus Edelstahl gefertigt. Die Klinge und der Griff sind gleich breit. Kann für Arbeiten in Ecken und in engen Öffnungen verwendet werden.

Apto para superficies de vidrio. Excelente resistencia a los disolventes. Igualmente, resistente contra el óxido. Se puede utilizar en trabajos de fontanería. Todas las piezas metálicas están hechas de acero inoxidable. Cuchilla y mango de la misma anchura. Se puede utilizar para trabajar en esquinas y aberturas estrechas.

## GSR-1/3B



FOR BOTH  
RIGHT- and LEFT-  
HANDED USERS



STAINLESS  
STEEL  
BLADE



ACETONE  
RESISTANT

GSB-1Sx4



GSB-1S



220X130X16.8 (mm)



6X10 (pcs.)

Blade width: 120mm

- Largeur de la lame : 120 mm
- Klingenbreite: 120 mm
- Anchura de la cuchilla: 120 mm



## GSR-2



FOR BOTH  
RIGHT- and LEFT-  
HANDED USERS



STAINLESS  
STEEL  
BLADE



ACETONE  
RESISTANT

GSB-2Sx6



GSB-2S/GSB-1S



220X95X17.8 (mm)



6X20 (pcs.)

Blade width: 40mm

Spare blades can be stored in the blade cover. The spare blade case mounts on the handle during use.

- Largeur de la lame : 40 mm
- Les lames de rechange peuvent être rangées dans le couvercle de la lame. La boîte de lame de rechange se monte sur la poignée pendant l'utilisation.
- Klingenbreite: 40 mm
- Ersatzklingen können in der Klingendeckung aufbewahrt werden. Das Ersatzklingengehäuse wird während des Gebrauchs am Griff befestigt.
- Anchura de la cuchilla: 40 mm
- Las cuchillas de repuesto pueden guardarse en la cubierta de la cuchilla. El estuche de cuchillas de repuesto se monta en el mango durante el uso.



## Japanese traditional Leather Knives / Razor Sharp Scrapers with refillable blades.

- Couteaux en cuir traditionnels japonais / Grattoirs lames échangeables.
- Traditionelle Japanische Ledermesser / Klingenschaber mit auswechselbarer Klinge.
- Cuchillos de cuero tradicionales japoneses / Rascadores de cuchilla recambiables.

## BTC-1/DX



FOR BOTH  
RIGHT- and LEFT-  
HANDED USERS



ONE-SIDED  
SHARPENING



ACETONE  
RESISTANT



BTB-1



240X116X25 (mm)



6X20 (pcs.)

With an adjustable head that can be used as a scraper or a knife

- Avec une tête réglable qui peut être utilisée comme grattoir ou couteau
- Mit einem verstellbaren Kopf, der als Schaber oder Messer verwendet werden kann
- Con un cabezal ajustable que puede utilizarse como rascador o cuchillo.

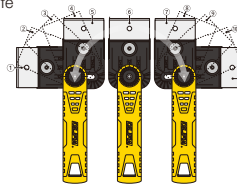

11 head orientation patterns



## BTC-1



FOR BOTH  
RIGHT- and LEFT-  
HANDED USERS



ONE-SIDED  
SHARPENING



BTB-1



220X95X20.3 (mm)



6X20 (pcs.)

Versatile scraper which works great to cut leather and resin sheets

- Grattoir polyvalent permettant de couper facilement le cuir et les feuilles de résine
- Vielseitige Abzieh Klinge, die sehr gut zum Schneiden von Leder und Kunststoffplatten geeignet ist
- Cuchilla versátil que funciona bien para cortar cuero y láminas de resina



### Handy scraper with unique multi-edged arc blade.

- Grattoir maniable avec lame en arc multi-tranchants.
- Handliches Schabmesser mit mehrschneidiger Bogenklinge.
- Raspador práctico con cuchilla de arco de varios filos.

#### T-45



TB-45



220×95×26 (mm)



3×40 (pcs.)

Blade width: 45mm

- Largeur de la lame : 45 mm
- Klingenbreite: 45 mm
- Anchura de la cuchilla: 45 mm



### Compact scrapers for cleaning floor & glass top oven.

- Grattoirs compacts pour le nettoyage des sols et des fours à porte en verre.
- Kompakt-Schabmesser zum Reinigen des Bodens & der Ofenglasdecke.
- Raspadores compactos para la limpieza de suelos y cubiertas de cristal dehornos.

#### SCR-S



220×80×15 (mm)



6×20 (pcs.)

Blade width: 25mm

- Largeur de la lame : 25 mm
- Klingenbreite: 25 mm
- Anchura de la cuchilla: 25 mm



#### SCR-M



220×80×15 (mm)



6×20 (pcs.)

Blade width: 43mm

- Largeur de la lame : 43 mm
- Klingenbreite: 43 mm
- Anchura de la cuchilla: 43 mm



#### SCR-L



220×80×15 (mm)



6×20 (pcs.)

Blade width: 60mm

- Largeur de la lame : 60 mm
- Klingenbreite: 60 mm
- Anchura de la cuchilla: 60 mm



# Rotary Cutters

OLFA's invention of the Rotary Cutter in 1979 totally changed the world of quilting, and delivered extraordinary convenience no one could imagine back then.



## Cutters rotatifs

L'invention du cutter rotatif d'OLFA en 1979 a totalement modifié le monde des techniques de piquage et livré une commodité extraordinaire que personne ne pouvait imaginer à l'époque.

## Rundmesser

OLFAs Erfindung des Rotationscutters 1979 veränderte die Welt der Quiltingtechniken komplett und bietet außergewöhnlichen Komfort, den sich bis dahin niemand vorstellen konnte.

## Cortadores rotativos

La invención del cortador rotativo de OLFA en 1979 cambió totalmente el mundo de las técnicas de acolchado y proporcionó una conveniencia extraordinaria que nadie podía imaginarse entonces.

### High cost-performance rotary cutter featuring Quick Change.

Cutter rotatif haute performance doté d'un changement rapide de lame.

Hochleistungs-Rotationsschneider mit schnellem Klingenswechsel.

Cúter giratorio de gran rendimiento con cambio de cuchilla rápido.



### RTY-2/C



PAT.



RB45/RB45H



219X114X21 (mm)



6X12 (pcs.)

Basic model for wide applications

- Modèle de base pour de multiples applications
- Grundmodell für umfangreiche Anwendungen
- Modelo básico para numerosas aplicaciones



### RTY-2C/YEL



PAT.



RB45/RB45H



219X114X21 (mm)



6X12 (pcs.)



### RTY-2C/PIK



PAT.



RB45/RB45H



219X114X21 (mm)



6X12 (pcs.)



### RTY-2C/NBL



PAT.



RB45/RB45H



219X114X21 (mm)



6X12 (pcs.)



### RTY-1/C



RB28/PRB28



220X80X16.2 (mm)



6X20 (pcs.)

Small model with 28mm blade

- Petit modèle avec lame de 28 mm
- Kleines Modell mit 28 mm Klinge
- Modelo reducido con cuchilla de 28 mm



The combination of Quick Change, split blade cover and ergonomic comfort Grip.

Association d'un changement rapide de lame, d'un couvercle de lame fendu et d'une poignée ergonomique confortable.

Eine Kombination aus schnellem Klängenwechsel, geteilter Klängenabdeckung und ergonomischem Komfortgriff.

Combinación de cambio de cuchilla rápida, cubierta de cuchilla dividida y empuñadura cómoda y ergonómica.

RTY-2/NS



RB45/RB45H



219X114X23 (mm)



6X12 (pcs.)

Perfect for various uses

- Parfait pour des utilisations variées
- Für verschiedene Verwendungen perfekt geeignet
- Perfecto para diferentes usos

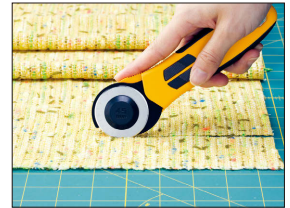

Safety locking system. Designed for reducing hand fatigue and potential injuries in the workshop.

La série DX dispose d'un système de verrouillage de sécurité. Conçu pour réduire la fatigue manuelle et les blessures potentielles sur le lieu de travail.

Die DX-Reihe bietet ein Sicherheitsverriegelungssystem. Entwickelt, um die Handermüdung und potentielle Verletzungen am Arbeitsplatz zu verringern.

La serie DX posee un sistema de bloqueo de seguridad. Diseñado para reducir el cansancio de la mano y posibles lesiones durante el trabajo.

RTY-2/DX



RB45/RB45H/  
PIB45/WAB45



220X113X28 (mm)



6X12 (pcs.)

45mm blade, can accommodate decorative blades as well

- Avec une lame de 45 mm, peut s'adapter aux lames décoratives
- Mit 45 mm Klinge, kann dekorative Klängen unterbringen
- Con cuchilla de 45 mm, puede acomodar cuchillas decorativas



RTY-3/DX



RB60/RB60H



250X125X29 (mm)



6X10 (pcs.)

Large model with 60mm blade

- Grand modèle avec lame de 60 mm
- Großes Modell mit 60 mm Klinge
- Modelo superior con cuchilla de 60 mm



Loved by many quilters and craft enthusiasts in the world since the launch in 1979. Simple and basic functions assist user's creativity for many years.

Apprécié par de nombreux artisans et amateurs de bricolage dans le monde depuis sa mise sur le marché en 1979. Ses fonctions de base simples aident à la créativité de son utilisateur depuis de longues années.

Von vielen Quilt-Herstellern und Handwerksbegeisterten weltweit seit der Einführung 1979 geliebt. Einfache und grundlegende Funktionen unterstützen über viele Jahre die Kreativität des Benutzers.

Adorado por muchos entusiastas de la artesanía y costura de todo el mundo desde su lanzamiento en 1979. Funciones simples y básicas para ayudar durante muchos años a la creatividad del usuario.

## RTY-2/G



RB45/RB45H



219X114X20 (mm)



6X20 (pcs.)

Basic model for wide applications

- Modèle de base pour de multiples applications
- Grundmodell für umfangreiche Anwendungen
- Modelo básico para numerosas aplicaciones



The Premium Quiltmaking Kit is the perfect gift for a beginner quilter, quilt class attendee, educator or teacher.

Le kit de matelassage premium est le cadeau idéal, parfait pour un débutant en matelassage, une personne qui va à des cours de matelassage ainsi que pour un formateur ou un enseignant.

Das Premium-Quilt-Herstellungset eignet sich hervorragend als besonderes Geschenk für einen Anfänger im Quilten, Quilt-Kursteilnehmer oder für Quilt-Lehrer.

El kit premium para costura es el regalo ideal para los costureros principiantes, los participantes de clases de costura, educadores o profesores.

## RTY-ST/QR

## RTY-ST/QR-METRIC

## RTY-ST/QR-RC

## RTY-ST/QR/METRIC-RC



RB45/RB45H



490X315X25 (mm)



5X5 (pcs.)

The premium Quiltmaking Kit Contains the RTY-2/G rotary cutter, RM-IC-C rotary mat (470 x 320 x 1.6mm) and kit-exclusive QR-6S or MQR-15 x 16 quilt ruler.

- Le kit de matelassage premium contient le cutter rotatif RTY-2/G, un tapis rotatif (470 x 320 x 1,6 mm) et une règle de matelassage QR-6S ou MQR-15x16 exclusive pour le kit.
- Das Premium-Quilt-Herstellungset enthält den RTY-2/G-Rotationscutter, die RM-IC-C-Rotationsmatte (470 x 320 x 1,6 mm) und exklusiv für das Set das QR-6S- oder MQR-15x16-Quilt-Lineal.
- El kit premium para costura contiene el cortador rotativo RTY-2/G, la estera giratoria RM-IC-C (470 x 320 x 1,6 mm) y el kit exclusivo QR-6S o la regla de costura MQR-15x16.

Inches



or

Metric



RTY-ST/QR  
RTY-ST/QR-METRIC



RTY-ST/QR-RC  
RTY-ST/QR-METRIC-RC

## RC version

### RTY-ST/QR-RC

### RTY-ST/QR/METRIC-RC

Environment-friendly DEHP-Free cutting mat designed for the European market

- Tapis de coupe sans DEHP, respectueux de l'environnement, conçu pour le marché européen
- Für den europäischen Markt konzipierte umweltfreundliche und DEHP-freie Schneidmatte
- Soporte para cortar libre de DEHP respetuoso con el medio ambiente diseñado para el mercado europeo

## RTY-3/G



RB60/RB60H



250X125X22.9 (mm)



6X20 (pcs.)

Largest model with powerful blade

- Modèle le plus grand avec lame puissante
- Größtes Modell mit kraftvoller Klinge
- El mayor modelo con una poderosa cuchilla

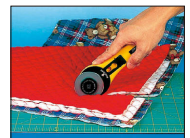

## RTY-4



RB18/PRB18



220X80X14 (mm)



6X20 (pcs.)

For detailed tasks

- Pour travaux détaillés
- Für detaillierte Arbeiten
- Para trabajos detallados



### CMP-3

STAINLESS  
STEEL  
BLADE



RB18



220×115×29 (mm)



6×20 (pcs.)

Cuts fabric in circle diameter of 4-22 cm

- Coupe des cercles de tissu d'un diamètre de 4 à 22 cm
- Schneidet Stoff mit einem Kreisdurchmesser von 4-22 cm
- Corta tela con un diámetro de círculo de 4-22 cm

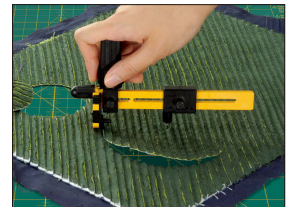

### CHN-1

FOR BOTH  
RIGHT- and LEFT-  
HANDED USERS



CHB



220×115×25.7 (mm)



6×10 (pcs.)

Chenille cutter with 4 channel guides

- Cutter chenille avec 4 guides de conduit
- Chenille-Messer mit 4 Führungskanälen
- Cortador de felpa con 4 guías de canal



### PRC-3/C

FOR BOTH  
RIGHT- and LEFT-  
HANDED USERS



PRB28/RB28



220×80×16 (mm)



6×20 (pcs.)

Featuring a 28 mm deep-serrated edged alloy tool steel blade, the PRC-3/C will be most welcomed for frequent users of perforated cutting. Quick Change with just a click.

- Doté d'une lame en alliage d'acier avec des dents de 28 mm, le PRC-3/C sera très apprécié par les utilisateurs fréquents de découpe perforée. Changement de lame rapide en un simple clic.
- Das PRC-3/C verfügt über eine Werkzeugklinge aus einer Stahllegierung mit einem 28 mm tiefen Wellenschliff und wird von Anwendern für häufige Perforationsschneidarbeiten bevorzugt. Schneller Klängenwechsel mit nur einem Klick.
- Con una hoja de aleación de acero con filo de dientes de sierra profundos y 28 mm, el PRC-3/C será la mejor elección para usuarios habituales del corte perforado. Cambio rápido de la cuchilla con un solo clic.



Cut sample (actual size)  
Line segment: 3mm  
Spacing: 1mm



## RB45H



45  
mm

Longer lasting blade than the standard RB45.  
Fits all the OLFA 45 mm RTY handles!

- Lame plus durable que la RB45 classique.  
S'adapte à toutes les poignées OLFA 45 mm RTY !
- Langlebigere Klinge als die Standard-RB45.  
Passend für alle OLFA 45 mm-RTY-Griffe!
- Cuchilla más duradera en comparación con la estándar RB45.  
¡Se adapta a todos los mangos RTY de 45 mm de OLFA!

RB45  
RB60

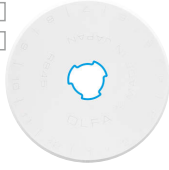

RB45H  
RB60H



Having a round hole, the RB45H/RB60H better fits the OLFA Rotary Cutters to provide quilters with the next level of user-friendliness.

- Dotée d'un trou circulaire, la RB45H/RB60H est mieux adaptée aux lames rotatives OLFA pour offrir plus de convivialité et de confort aux adeptes du quilting.
- Mit einem runden Loch passt das RB45H/RB60H besser an die OLFA-Drehmesser und bietet Quiltern somit ganz neuen Komfort.
- Con un orificio redondo, el RB45H/RB60H se adapta mejor a los cortadores rotativos OLFA para proporcionar acolchados con un nivel de usabilidad superior.

## RB60H

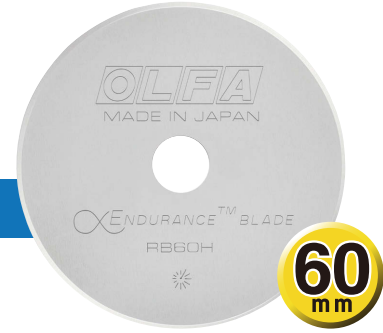

60  
mm

Longer lasting blade than the standard RB60.  
Fits all the OLFA 60 mm RTY handles!

- Lame plus durable que la RB60 classique.  
S'adapte à toutes les poignées OLFA 60 mm RTY !
- Langlebigere Klinge als die Standard-RB60.  
Passend für alle OLFA 60 mm-RTY-Griffe!
- Cuchilla más duradera en comparación con la estándar RB60.  
¡Se adapta a todos los mangos RTY de 60 mm de OLFA!

# Quilt Rulers

Non-slip, frosted surface acrylic rulers.  
Legible grid lines on both light and dark colored fabrics.

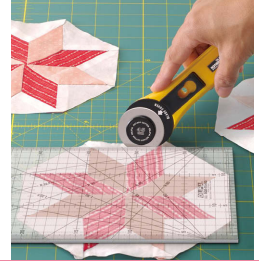

### Règles de matelassage

Règle en acrylique avec surface dépolie antidérapante. Lignes de la grille lisibles à la fois sur les tissus de couleur claire et foncée.

### Quilt-Lineale

Rutschfest, mattierte Oberfläche Acryllineale. Lesbare Gitterlinien sowohl auf hellen als auch auf dunkelfarbigen Stoffen.

### Reglas de costura

Reglas acrílicas de superficie mate anti deslizantes. Líneas de cuadrícula legibles en telas con colores oscuros y claros.

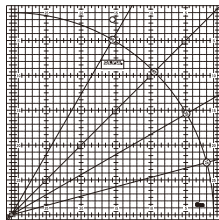

MQR-30x30

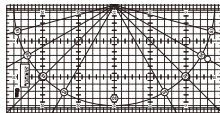

MQR-15x30

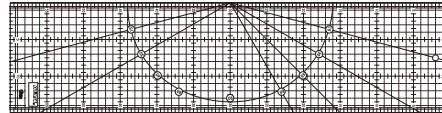

MQR-15x60

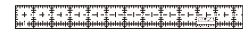

QR-1x12

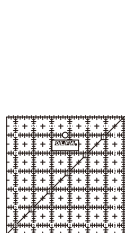

QR-6S

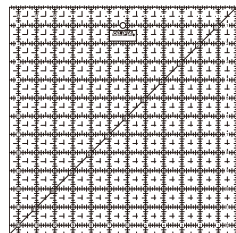

QR-12S

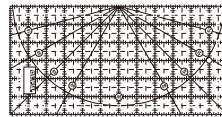

QR-6x12

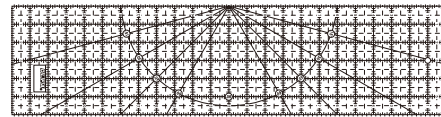

QR-6x24

### MQR-30x30



308×308×3 (mm)



6×8 (pcs.)

30cmx30cm

### MQR-15x30



300×150×3 (mm)



6×8 (pcs.)

15cmx30cm

### MQR-15x60



600×150×3 (mm)



6×8 (pcs.)

15cmx60cm

### QR-1x12



318×33×3 (mm)



12×20 (pcs.)

1 (1/4)"x12.5"

### QR-6S



166×166×3 (mm)



6×10 (pcs.)

6.5"x6.5"

### QR-12S



318×318×3 (mm)



6×4 (pcs.)

12.5"x12.5"

### QR-6x12



306.5×153×3 (mm)



6×8 (pcs.)

6"x12"

### QR-6x24



610×153×3 (mm)



6×4 (pcs.)

6"x24"

# Other Purpose-Made Hand Tools



Wide array of cutting tools best suited for every idea, every cutting material, and every working environment.

## Autres outils manuels pour usage spécifique

Le large éventail d'outils de coupe les mieux adaptés pour chaque idée, chaque matériau de coupe, et chaque environnement de travail de coupe.

## Andere speziell angefertigte Handwerkzeuge

Das umfangreiche Sortiment an Schneidwerkzeugen, die am besten für jede Idee, jedes Schneidmaterial und jede Arbeitsumgebung passen.

## Otras herramientas manuales hechas a propósito

La amplia gama de las herramientas de corte que mejor se adapta a cada idea, cada material de corte y cada entorno de trabajo.



Other Purpose-Made Hand Tools

## LTD-AK



**KBx25**



KB/KB4-S/KB4-R/  
KB4-F/KB4-NF



220x80x15 (mm)



6x20 (pcs.)

Pen-type art knife designed for workmanship, suitable for model-making and other delicate work of art.

- Couteau d'art de type stylo conçu pour le travail, adapté au modélisme et autres travaux d'art délicats.
- Stiftförmiges Bastelmesser, das sich für den Modellbau und andere filigrane Kunstwerke eignet.
- Cuchillo artístico tipo bolígrafo diseñado para trabajos manuales, artes gráficas, adecuado para modelismo y otros trabajos artísticos delicados.



## AK-4



**KB4-Sx2**



**KB4-Fx1**



**KB4-Rx1**



KB4-S/KB4-R/KB4-F/  
KB4-NF/KB4-SC/KB4-P/  
KB4-NS/KB4-WS/KB



220x95x17.1 (mm)



6x20 (pcs.)

Premium art knife with soft grip

- Couteau d'art de qualité supérieure avec poignée molle
- Erstklassiges Kunstmesser mit weichem Griff
- Cortador artístico premium con mango suave



KB4-S

KB4-R

KB4-F

KB4-NS



x2

x1

x1

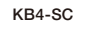
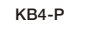

KB4-S

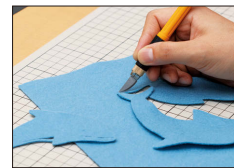

KB4-R

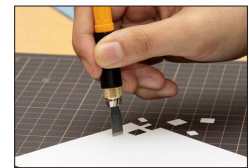

KB4-F

## KB4-S/100



45x52x10 (mm)



10x5

100 blades packed in economical package

- 100 lames dans un boîtier d'emballage économique
- 100 Klingen, die verbrauchsarm verpackt sind
- 100 cuchillas incluidas en un embalaje económico

KB4-S/100



x100



## AK-1



**KBx25**



KB



220x80x14.6 (mm)



6x20 (pcs.)

## AK-1/5B



**KBx5**



KB



220x80x10 (mm)



6x40 (pcs.)

Basic art knife

- Couteau d'art de base
- Einfaches Kunstmesser
- Cortador artístico básico



## AK-5



**KB-5x30**

**Needle x1**



KB-5



220X65X16(mm)



6X20(pcs.)

**AK-5/5B**

**AK-5/5B/BLK**

**AK-5/5B/BLU**

**AK-5/5B/PIK**



**KB-5x5**



KB-5



220X65X13(mm)



6X40(pcs.)

The sharp-pointed blade is perfect for precise cutting.  
The spare blade case works as a stand when connected to the blade cover.

La lame à bout pointu est parfaite pour assurer la précision de coupe. La boîte de lame de rechange fonctionne comme un standish lorsqu'il est connecté au cache de la lame.

Die Klinge mit scharfer Spitze ist perfekt für präzises Schneiden. Der Ersatzklingenbehälter dient als Ständer, wenn er an der Klingensabdeckung befestigt ist.

La cuchilla afilada puntiaguda es perfecta para un corte de precisión. El estuche de la cuchilla de repuesto caso funciona como un soporte al conectarla a la cubierta de la cuchilla.



AK-5/5B/BLK



AK-5/5B/BLU



AK-5/5B/PIK

## ESK-1



**ESKB-1**



ESKB-1



220X80X35(mm)



6X12(pcs.)

Entry level type snap-off blade utility knife, could possibly be your first utility knife!

Le couteau tout usage à lame cassable d'entrée de gamme pourrait être votre premier couteau tout usage!

Dieses Einsteiger-Universalmesser mit Abbrechklinge kann Ihr erstes Universalmesser sein!

Esta cuchilla multiusos básica desmontable podría ser su primera cuchilla multiusos!



ESK-1  
Paper Box Package



## TS-1



**TSB-1x3**



TSB-1



220X80X13(mm)



6X20(pcs.)

Incredible, cuts only the top sheet

Incredibly, permet de ne couper que la feuille supérieure

Unglaublich, schneidet nur das obere Blatt

Increible, corta únicamente la hoja superior



### PK-1



120x51x21 (mm)



20x10 (pcs.)

Opens sealed packages such as vacuum packaging and food packages.

- ouvre les emballages scellés tels que les emballages sous vide et les emballages alimentaires.
- Öffnet versiegelte Verpackungen wie Vakuumpackungen und Lebensmittelverpackungen.
- Abre paquetes envasados o sellados al vacío, es ideal abrir artículos de alimentación.



### TK-3M/24



498x219x12 (mm)



24x30 (pcs.)

Magnetic Touch Knife

- Couteau tactile magnétique
- Magnetisches Kontaktmesser
- Cortador magnético de bolsillo



### TK-4/60



221x196x65 (mm)



60x20 (pcs.)

### TK-4/32



639x235x9 (mm)



32x30 (pcs.)

Compact and convenient cutter

- Cutter compact et pratique
- Kompaktes und bequemes Schneidmesser
- Cúter compacto y útil



TK-4/60



TK-4/32



### TK-5M/48



218x196x67 (mm)



48x20 (pcs.)

Magnetic Touch Knife in 4 calm colors.

- Couteau magnétique tactile décliné en 4 couleurs apaisantes.
- Magnetisches Touch-Messer in 4 bedeckten Farben
- Cutter magnético táctil en 4 colores calidos

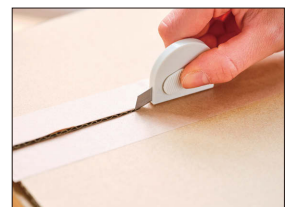

## HOK-1



HOB-1

220×95×21 (mm)

6×20 (pcs.)

Powerful hook cutter

- Cutter à crochet puissant
- Kraftvolles Hakenmesser
- Cortador de gancho potente



## MC-45



ONE-SIDED SHARPENING



MCB-1x6

MCB-1

220×92×60 (mm)

6×10 (pcs.)

## MC-45/2B



ONE-SIDED SHARPENING



MCB-1x2

MCB-1

220×92×60 (mm)

6×10 (pcs.)

45° oblique cutting, great for picture mounts

- Coupe oblique à 45°, idéal pour les encadrements
- 45° schräges Schneiden, großartig für Bilderhalterungen
- Corte oblicuo de 45° excelente para montajes de imágenes



## PC-L



PB-800x3

PB-800

220×80×23 (mm)

6×20 (pcs.)

Plastic Cutters housing 2 extra blades inside. Score on plastic plate to break off.

- Cutters en plastique avec 2 lames supplémentaires. Notation sur plaque en plastique pour découpe.
- Plastikmesser mit 2 extra Klingen. Zum Abbrechen auf Kunststoffplatte anritzen.
- Cortadores de plástico con 2 cuchillas adicionales. Raya placas de plástico para posteriormente romperlas.



## PC-S



PB-450x3

PB-450

220×80×17 (mm)

6×20 (pcs.)

Plastic Cutters housing 2 extra blades inside. Score on plastic plate to break off.

- Cutters en plastique avec 2 lames supplémentaires. Notation sur plaque en plastique pour découpe.
- Plastikmesser mit 2 extra Klingen. Zum Abbrechen auf Kunststoffplatte anritzen.
- Cortadores de plástico con 2 cuchillas adicionales. Raya placas de plástico para posteriormente romperlas.

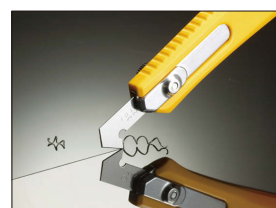

### UTC-1



	SKB-2/SKB-2S-R/SKB-2S/R RSKB-2/HOB-2		220×80×25 (mm)		6×20 (pcs.)
---	---	---	----------------	---	-------------

A powerful utility knife for a wide range of tasks

- | Un couteau tout usage résistant pour une large gamme de tâches
- | Ein leistungsstarkes Universalmesser für eine Vielzahl von Aufgaben
- | Una potente cuchilla multiusos para una amplia gama de tareas



### SK-3



	SKB-2/SKB-2S/SKB-2S-R/ RSKB-2/HOB-2		220×80×20 (mm)		6×40 (pcs.)
---	--	---	----------------	---	-------------

Features 1 spare blade in the handle. Accommodates both right- and left-handed users.

- | Contient 1 lame de rechange dans la poignée. Adapté aux droitiers et aux gauchers.
- | Enthält 1 Ersatzklinge im Griff. Sowohl für Rechts- als auch für Linkshänder geeignet.
- | Incluye 1 cuchilla de repuesto en el mango. Apta tanto para usuarios diestros como zurdos.



### CTN-1



	CTB		160×63×8.2 (mm)		24×20 (pcs.)
---	-----	---	-----------------	---	--------------



CTN-1

### CTN-1/40



	CTB		197×127×77 (mm)		40×12 (pcs.)
---	-----	---	-----------------	---	--------------

Carton cutter with snap-off blade

- | Cutter à carton avec lame sécable
- | Kartonmesser mit Abknick-Klinge
- | Cortador para cartón con cuchilla desglposable



CTN-1/40

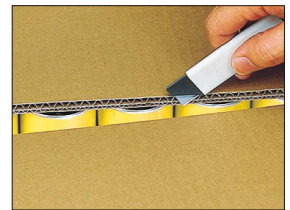

### 45-C



	RB45		240×115×27 (mm)		6×10 (pcs.)
---	------	---	-----------------	---	-------------

Carpet/Lino cutter

- | Cutter pour moquette/lino
- | Teppich- / Linoleummesser
- | Cortador de moqueta / lino



## CMP-1



COB-1x6



COB-1



220X95X25 (mm)



6X20 (pcs.)

Cuts circles in diameter 1-15 cm

- | Permet de découper des cercles de 1 à 15 cm de diamètre
- | Schneidet Kreise im Durchm. 1 - 15 cm
- | Corta círculos en diámetros de 1 a 15 cm

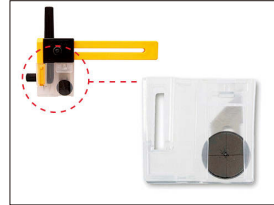

## CMP-1/DX



COB-1x11



COB-1



220X130X26 (mm)



6X20 (pcs.)

Ratchet circle cutter in diameter 1.6-22cm

- | Cutter rotatif à rochet de diamètre de 1.6 à 22 cm
- | Knarrenkreismesser im Durchm. 1.6 - 22 cm
- | Cortador con carrete que corta círculos de diámetro de 1.6 a 22 cm

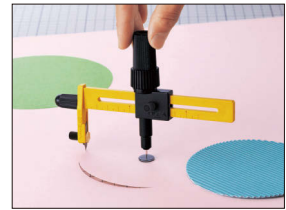
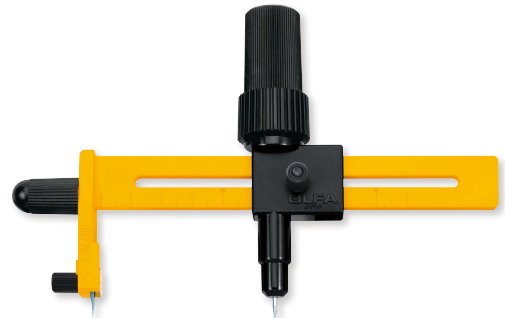

## CK-1



CKB-1



220X50X11.2 (mm)



6X40 (pcs.)

Craft knife for wood carving and hobby crafts

- | Couteau d'artisanat pour la sculpture du bois et les activités de loisir
- | Handwerksmesser für die Holzschnitzerei und Hobbyhandwerkskunst
- | Cuchilla de manualidades para el tallado de madera y artesanías no profesionales

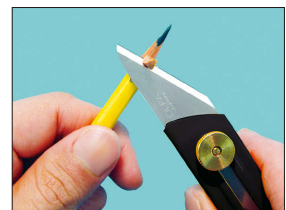

## CK-2



CKB-2



220X70X12.9 (mm)



6X40 (pcs.)

Stainless steel model

- | Modèle en acier inoxydable
- | Edelstahlmodell
- | Modelo de acero inoxidable

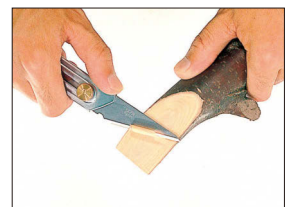

# Cutting Mats



Self-healing cutting mats designed by the originator of the snap-off blade cutter, best used with OLFA cutters, art knives, and rotary cutters. Mats protect cutting surfaces and improve the blades' life as well.



## Tapis de coupe/Tapis rotatifs

Tapis de coupe auto-cicatrisant conçu par l'inventeur de la lame cassable, utilisation optimale avec les cutters OLFA, les couteaux d'art et les cutters rotatifs. Les tapis protègent les surfaces de coupe et améliorent également la durée de vie des lames.

## Schneidmatten/Rotationsschneidmatten

Selbstheilende Schneidmatten, die vom Erfinder des Abbrechklingmessers entwickelt wurden und am besten mit OLFA-Schneidern, Kunstmessern und Rotationsschneidern verwendet werden. Die Matten schützen die Schneideoberflächen und erhöhen außerdem die Lebensdauer der Klingen.

## Alfombrillas de corte/alfombrillas giratorias

Alfombrillas de corte autorreparables diseñadas por el creador del cutter de hoja desmontable, utilizadas especialmente con cutter OLFA, cuchillas para arte y cutter giratorios. Las alfombrillas protegen las superficies de corte y también alargan la vida útil de las cuchillas.

**thickness 3mm**

**Folding mats are a good size for carrying and storage, designed for heavy-duty cutting.**

Le tapis Olefin, respectueux de l'environnement, est plus facilement transportable grâce à sa taille plus petite une fois plié.  
La taille des tapis repliables est idéale pour le transport et le rangement et ils sont conçus pour une coupe intensive.

Die umweltfreundliche Olefin-Matte ist dank ihrer kleineren und faltbaren Größe tragbarer.  
Zusammenklappbare Matten lassen sich gut tragen und verwahren und sind für das Schwerlastschneiden konstruiert.

Su menor tamaño plegado hace que esta estera Olefin ecológica sea más portátil.  
Las esteras plegables tienen el tamaño de transporte y almacenamiento ideal y han sido diseñadas para el corte industrial.

## FCM-A2

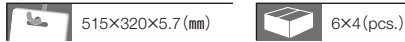

Mat:(During use)450mm x 620mm x 3mm / (When folded)450mm x 315mm x 6mm

- Tapis : (Pendant l'utilisation)450mm x 620mm x 3mm / (Une fois replié)450mm x 315mm x 6mm
- Matte: (Beim Gebrauch)450mm x 620mm x 3mm / (Zusammengeklappt)450mm x 315mm x 6mm
- Estera: (durante el uso) 450 mm x 620 mm x 3mm / (plegada) 450 mm x 315 mm x 6mm

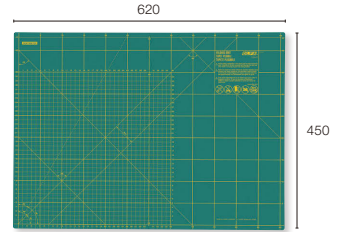
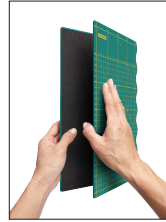

## FCM-A3

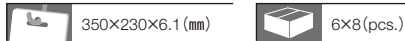

Mat:(During use)320mm x 450mm x 3mm / (When folded)320mm x 230mm x 6mm

- Tapis : (Pendant l'utilisation)320mm x 450mm x 3mm / (Une fois replié)320mm x 230mm x 6mm
- Matte: (Beim Gebrauch)320mm x 450mm x 3mm / (Zusammengeklappt)320mm x 230mm x 6mm
- Estera: (durante el uso) 320mm x 450mm x 3mm / (plegada) 320mm x 230mm x 6mm

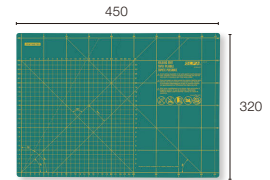
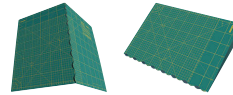

**thickness 3mm**

**360° Rotating Mat for scrap booking, paper crafts, quilting and modelling.**

Tapis rotatif à 360° pour scrapbooking, créations en papier, matelassage et modélisation.

360°-Rotationsschneidematte für den Verschnitt von Büchern, Papierbasteleien, Quilten und Modellieren.

Alfombrilla giratoria, a 360°, para "scrapbooking", manualidades con papel, enguatado y modelado.

## RM-17S



17.32"x17.32"x0.24"/440x440x6

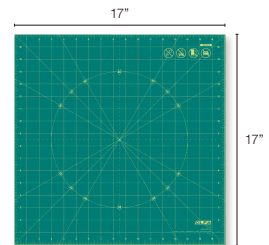
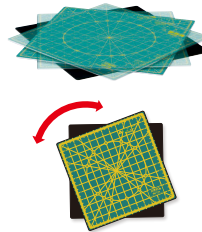

Scale: Inches

## **PAT.**

## RM-12S

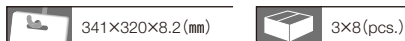

12.6"x12.6"x0.24"/320x320x6

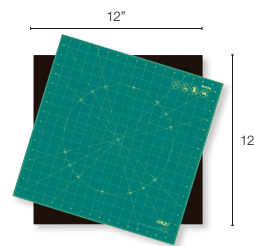
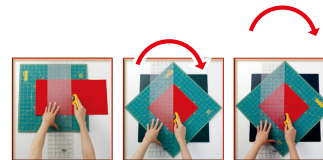

Scale: Inches

## RM-30x30

## RM-30x30-RC \*

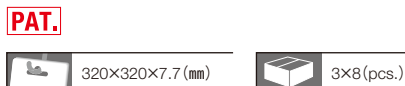

12.6"x12.6"x0.24"/320x320x6



Scale: Inches

## RC version

### RM-30x30-RC \*

Environment-friendly DEHP-Free cutting mat designed for the European market.

- Tapis de coupe sans DEHP, respectueux de l'environnement, conçu pour le marché européen.
- Für den europäischen Markt konzipierte umweltfreundliche und DEHP-freie Schneidmatte.
- Soporte para cortar libre de DEHP respetuoso con el medio ambiente diseñado para el mercado europeo.

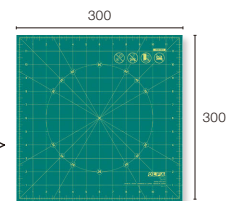

Scale: Metric

thickness  
**2mm**



Most suitable for hobby and craft work. Grids on both sides (cm/inch). Double-sided.

Idéal pour le travail artisanal et les loisirs. Grilles sur les deux côtés (cm/pouce). Double face.

Die beste Wahl für Hobby- und Handwerksarbeiten. Gitter an beiden Seiten (cm/Zoll). Beidseitig.

Muy adecuada para trabajos artesanales y manualidades. Cuadrículas en ambos lados (cm/pulgadas). Doble cara.

**CM-A1**

**CM-A1-RC** \*



5x2 (pcs.)

630x940x2/24.8"x37.01"x0.08"

**CM-A2**

**CM-A2-RC** \*



5x4 (pcs.)

450x620x2/17.72"x24.41"x0.08"

**CM-A3**

**CM-A3-RC** \*



5x12 (pcs.)

320x450x2/12.6"x17.72"x0.08"

**CM-A4**

**CM-A4-RC** \*



5x20 (pcs.)

225x320x2/8.86"x12.6"x0.08"

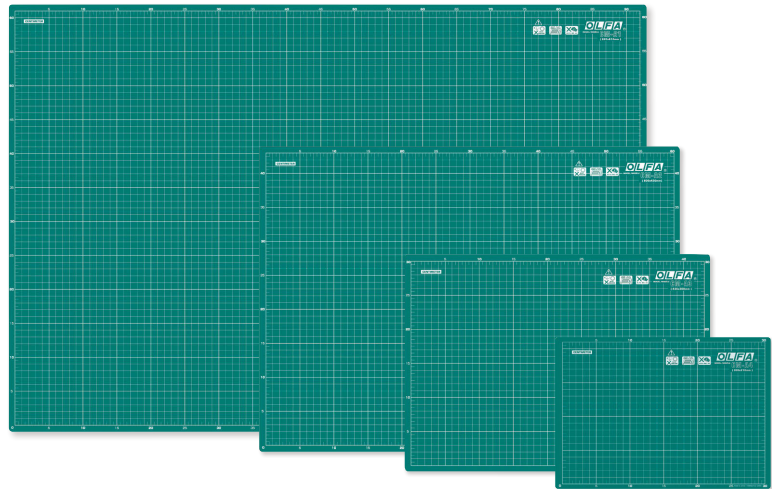

### RC version

**CM-A1-RC** \* **CM-A3-RC** \*  
**CM-A2-RC** \* **CM-A4-RC** \*



Environment-friendly DEHP-Free cutting mat designed for the European market.

Tapis de coupe sans DEHP, respectueux de l'environnement, conçu pour le marché européen.

Für den europäischen Markt konzipierte umweltfreundliche und DEHP-freie Schneidmatte.

Soporte para cortar libre de DEHP respetuoso con el medio ambiente diseñado para el mercado europeo.

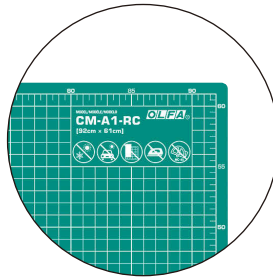

thickness  
**3mm**



Deluxe cutting mat for the best combination with our knives and rotary cutters. Double-sided.

Tapis de coupe Deluxe pour la meilleure association avec nos couteaux et cutters rotatifs. Double face.

Deluxe-Schneidmatte für die beste Kombination mit unseren Messern und Rotationsschneidern. Beidseitig.

Alfombrilla de corte de lujo para obtener la mejor combinación con nuestras cuchillas y nuestros cutteres giratorios. Doble cara.

**NCM-L-RC** \*



5pcs. (pcs.)

620x900x3/24.41"x35.43"x0.12"

**NCM-M-RC** \*



10pcs. (pcs.)

450x620x3/17.72"x24.41"x0.12"

**NCM-S-RC** \*



20pcs. (pcs.)

300x450x3/11.81"x17.72"x0.12"

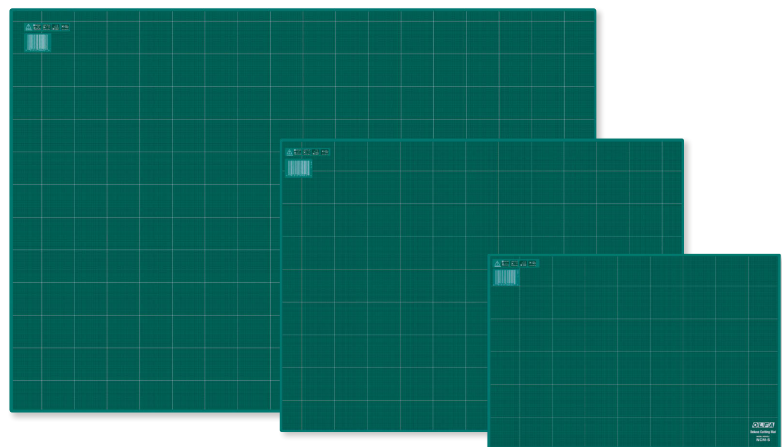

**NCM-L-RC** \* **NCM-M-RC** \*  
**NCM-S-RC** \*



Environment-friendly DEHP-Free cutting mat designed for the European market.

Tapis de coupe sans DEHP, respectueux de l'environnement, conçu pour le marché européen.

Für den europäischen Markt konzipierte umweltfreundliche und DEHP-freie Schneidmatte.

Soporte para cortar libre de DEHP respetuoso con el medio ambiente diseñado para el mercado europeo.

thickness  
**1.6mm**



Designed for use with our Rotary cutters. Self-healing triple layer mats. Double-sided.

Conçu pour être utilisé avec nos cutters rotatifs. Tapis triple couche auto-cicatrisants. Double face.

Für die Verwendung mit unseren Rotationschneidern vorgesehen. Selbstheilende dreilagige Matten. Beidseitig.

Diseñada para ser usada con nuestros cúteres giratorios. Alfombrillas de tres capas autorreparables. Doble cara.

**RM-MG**



5 (pcs.)

630x940x1.6/24.8"x37.01"x0.06"

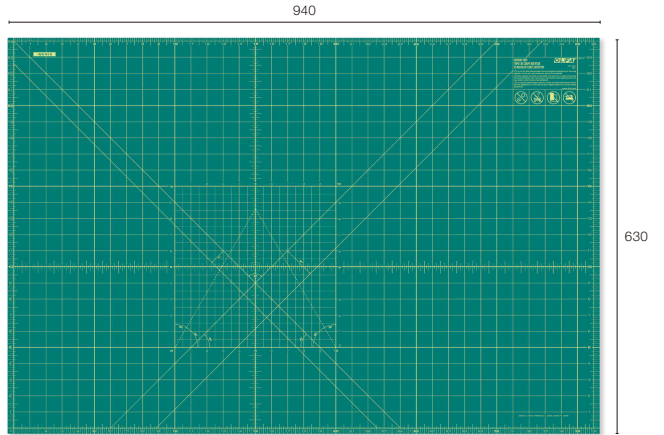

**RM-SG**



5x4 (pcs.)

470x630x1.6/18.5"x24.8"x0.06"

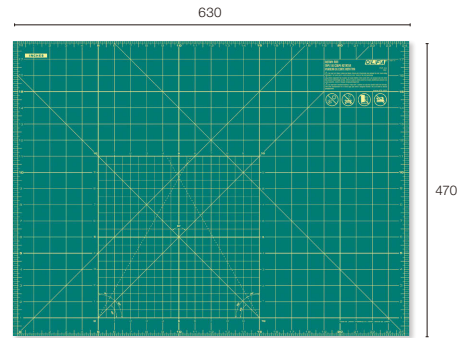

**RM-CG**



5x8 (pcs.)

320x470x1.6/12.6"x18.5"x0.06"

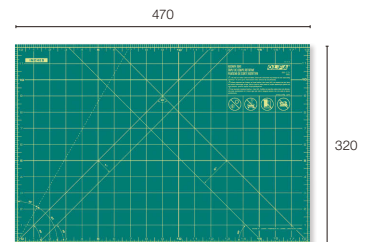

**RM-IC-M**  
**RM-IC-M-RC** \*

5x2 (pcs.)

630x940x1.6/24.8"x37.01"x0.06"

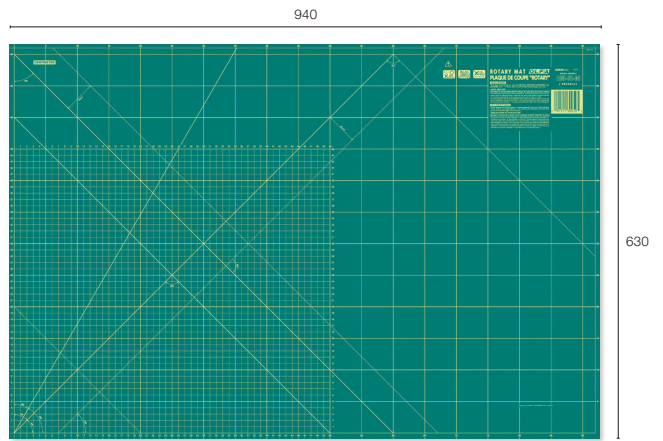

**RM-IC-S**  
**RM-IC-S-RC** \*

5x4 (pcs.)

470x630x1.6/18.5x24.8x0.06"

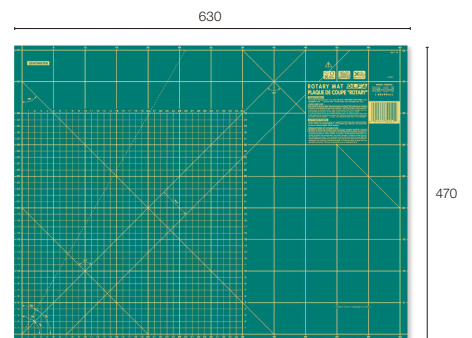

**RM-IC-C**  
**RM-IC-C-RC** \*

5x8 (pcs.)

320x470x1.6/12.6x18.5x0.06"

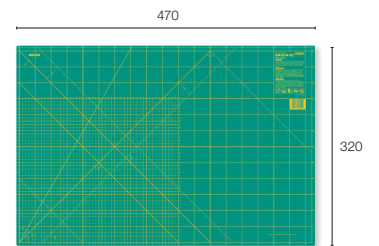

**RM-IC-C/PIK**  
**RM-IC-C-RC/PIK** \*

5x8 (pcs.)

320x470x1.6/12.6x18.5x0.06"

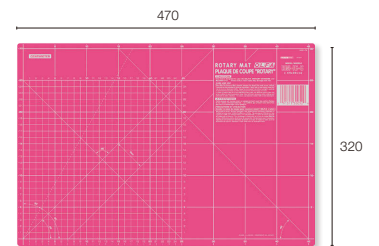

**RM-IC-C/AQA**  
**RM-IC-C-RC/AQA** \*

5x8 (pcs.)

320x470x1.6/12.6x18.5x0.06"

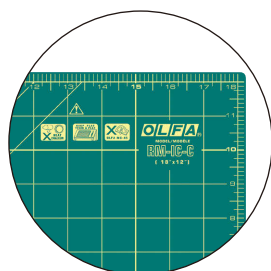
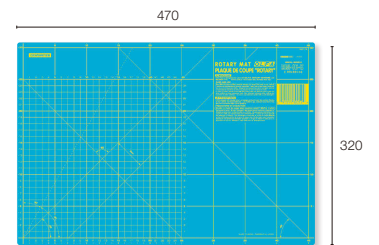

**RC version**

- RM-IC-M-RC** \* **RM-IC-S-RC** \* **RM-IC-C-RC** \*
- RM-IC-C-RC/PIK** \* **RM-IC-C-RC/AQA** \*



Environment-friendly DEHP-Free cutting mat designed for the European market.

- Tapis de coupe sans DEHP, respectueux de l'environnement, conçu pour le marché européen.
- Für den europäischen Markt konzipierte umweltfreundliche und DEHP-freie Schneidmatte.
- Soporte para cortar libre de DEHP respetuoso con el medio ambiente diseñado para el mercado europeo.



# Custom Logo Printing

## SK-15

Size of Printable area: W40xH10mm  
\*Pad Printing



## BN-L

Size of Printable area: W82xH13mm  
\*Pad Printing



## MT-1

Size of Printable area:  
<A> Body: W40 x H5.5mm  
<B> Clip: W22xH8mm  
\*On-demand Printing



## SK-4

Size of Printable area: W50xH5mm  
\*Silkscreen Printing



## TK-4

Size of Printable area:  
<A> Front: W21xH8mm  
<B> Back: W35xH27mm  
\*On-demand Printing

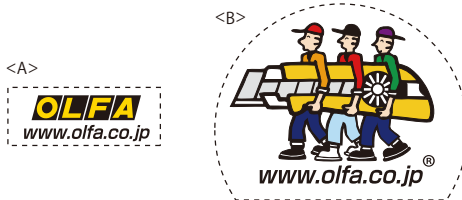

## TK-3M

Size of Printable area: W15xH6mm  
\*Hot stamping



## L-1

Size of Printable area: W27xH7mm  
\*Original Plate



\* Many more printable products available \*Printing method and design will vary by model





48  $\pm 0.35\text{mm}$

49  $\pm 0.35\text{mm}$

50  $\pm 0.35\text{mm}$

55  $\pm 0.3\text{mm}$

56  $\pm 0.3\text{mm}$

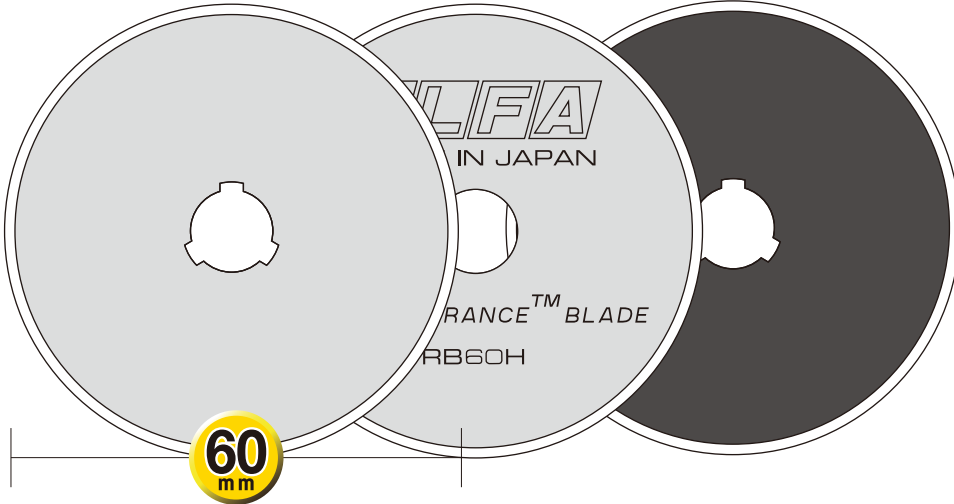

60 mm

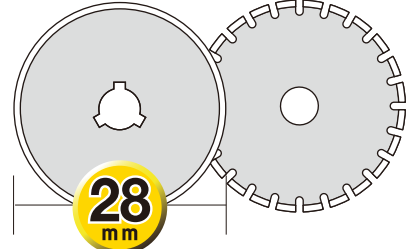

28 mm

57  $\pm 0.3\text{mm}$

58  $\pm 0.3\text{mm}$

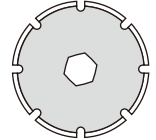
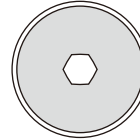

18 mm

18 mm

51  $\pm 0.3\text{mm}$

52  $\pm 0.3\text{mm}$

53  $\pm 0.4\text{mm}$

54  $\pm 0.4\text{mm}$

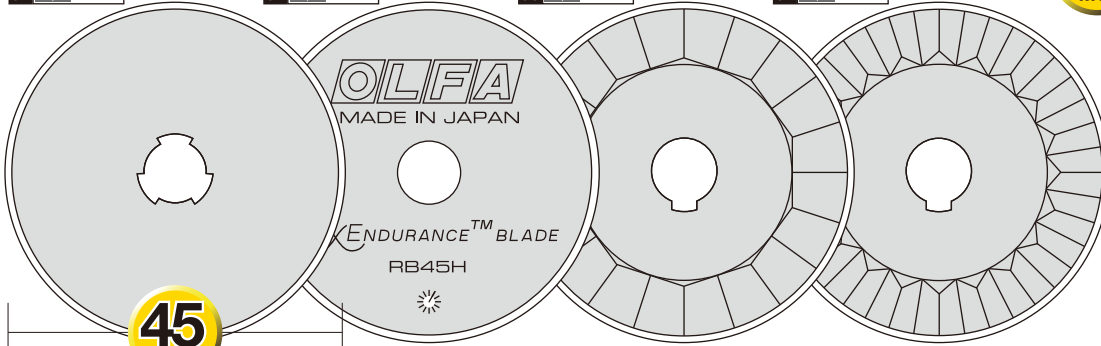

45 mm

60  $\pm 0.5\text{mm}$



61  $\pm 0.8\text{mm}$



59  $\pm 0.45\text{mm}$



62  $\pm 0.45\text{mm}$



63  $\pm 0.6\text{mm}$

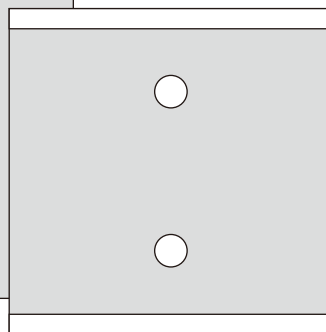

64  $\pm 0.7\text{mm}$

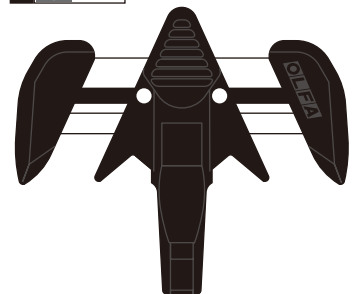

65  $\pm 0.25\text{mm}$



66  $\pm 0.25\text{mm}$



Model Number	Packaging	Contents	Carton Contents	Blister Packed	Plastic Case	Plastic Bag	Paper Box	
Numéro du Modèle Modell Nummer Número de Modelo	Emballage Verpackung Embalaje	Contenu Kartoninhalt Contenido	Contenu de Carton Kartoninhalt Contenido de Embalaje	Emballage Blister Blister Packing Presentado en Blister	Etui Plastique Kunststoffbox Caja de Plástico	Sachet Plastique Kunststoffbeutel Bolsa de Plástico	Boîte en papier Papierverpackung Caja de papel	
Appearance	Application	Appearance	Application	Appearance	Application	Appearance	Application	
Apparence Aussehen Apariencia	Application Anwendung Aplicación	Apparence Aussehen Apariencia	Application Anwendung Aplicación	Apparence Aussehen Apariencia	Application Anwendung Aplicación	Apparence Aussehen Apariencia	Application Anwendung Aplicación	
<b>1</b>  HB	HB-5B		5 6x20		H-1, NH-1, XH-1, XH-AL, HSW-1	HB-20	20 6x10	
	<b>2</b>  HBB	HBB-5B	5 6x20					
<b>3</b>  LB	LB-6B		6 6x40	OL, SL-1, ML, L-1, L-1/green, L-2, XL-2, EXL, BN-L, BN-AL, PL-1, L-5, L5-AL, L-7, L7-AL, L8-AL, MXP-L, MXP-AL, WD-L, WD-AL, LTD-L, LTD-AL, DL-1, CMP-2, XSR-200, XSR-300, XSR-600	LB-10	10 6x40		
	LB-10B		10 6x20		LB-30B	30 6x6		
	LB-50		50 6x10		LB-50B	50 6x6		
	LB-50B		50 6x6		LBB-10	10 6x40		
	<b>4</b>  LBB	LBB-10B			10 6x20	OL, SL-1, ML, L-1, L-1/green, L-2, XL-2, EXL, BN-L, BN-AL, PL-1, L-5, L5-AL, L-7, L7-AL, L8-AL, MXP-L, MXP-AL, WD-L, WD-AL, LTD-L, LTD-AL, DL-1, CMP-2	LBB-30B	30 6x6
	LBB-50B		50 6x6		LBB-50		50 6x10	
	<b>5</b>  LFB	LFB-5B			5 6x20		OL, SL-1, ML, L-1, L-1/green, L-2, XL-2, EXL, BN-L, BN-AL, PL-1, L-5, L5-AL, L-7, L7-AL, L8-AL, MXP-L, MXP-AL, WD-L, WD-AL, LTD-L, LTD-AL	<b>6</b>  LWB
<b>7</b>  LBD	LBD-10		10 6x40	OL, L-1, L-1/green, L-2, XL-2, EXL, BN-L, BN-AL, PL-1, L-5, L5-AL, L-7, L7-AL, L8-AL, MXP-L, MXP-AL, WD-L, WD-AL, LTD-L, LTD-AL, DL-1, CMP-2	LBD-50			50 6x10
<b>8</b>  LB-SOL	LB-SOL-10		10 6x40		OL, SL-1, ML, L-1, L-1/green, L-2, XL-2, EXL, BN-L, BN-AL, PL-1, OL-1, L-5, L5-AL, L-7, L7-AL, L8-AL, MXP-L, MXP-AL, WD-L, WD-AL, LTD-L, LTD-AL	<b>9</b>  SKB-7	SKB-7/10B	10 6x40
<b>10</b>  SKB-8	SKB-8/10B		10 6x40	SK-7, SK-7/green	<b>11</b>  SKB-10	SKB-10/10B	10 6x40	
<b>12</b>  RSKB-2	RSKB-2/5		5 6x40	SK-8	<b>13</b>  CTB	CTB-5	5 24x20	
<b>14</b>  SKB-2	SKB-2/5B		5 6x40	SK-10	SK-4, SK-4/green, SK-5, SK-9, SK-3, UTC-1	SKB-2/50	50 6x6	
<b>15</b>  SKB-2S	SKB-2S/10B		10 6x40	<b>16</b>  SKB-2S-R		SKB-2S-R/10B	10 6x40	
<b>17</b>  CKB-1	CKB-1		2 6x40	CK-1	<b>18</b>  CKB-2	CKB-2	2 6x40	
<b>19</b>  FWB	FWB-10		10 6x40	FWP-1	<b>20</b>  MTB	MTB-10B	10 6x40	
<b>21</b>  MTBB	MTBB-10B		10 6x40	MT-1, XMT-1, CS-5	<b>22</b>  AB	AB-6	6 10x60	
<b>23</b>  AB-S	AB-10		10 6x40	180Black, SVR-1, SVR-2, 300, A-2, A-3, S, SPC-1, ES-1/green, A-5, PA-2, XA-1, DA-1, A-1	ASB-10	10 12x60		
	AB-10B		10 6x40		AB-50	50 6x20		
	ASB-10S		10 12x60		AB-50B	50 6x20		
	AB-10S		10 6x40		ASB-10S	10 12x60		
	AB-50S		50 6x20		AB-10S	10 6x40		
	ASBB-10		10 12x60		AB-50S	50 6x20		
<b>24</b>  ABB	ABB-10B		10 6x40	ABB-50	50 6x20			
<b>25</b>  AB-SOL	AB-SOL-50		50 6x20	180Black, SVR-1, SVR-2, 300, A-2, S, SPC-1, ES-1/green, A-5, XA-1, A-1	<b>26</b>  SAB	SAB-10	10 10x60	
<b>27</b>  DKB	DKB-5		5 100x10	SAC-1	SAB-10B	10 6x40		

Model Number	Packaging	Contents	Carton Contents	Blister Packed	Plastic Case	Plastic Bag	Paper Box		
Numéro du Modèle Modell Nummer Número de Modelo	Emballage Verpackung Embalaje	Contenu Kartoninhalt Contenido	Contenu de Carton Kartoninhalt Contenido de Embalaje	Emballage Blister Blister Packing Presentado en Blister	Etui Plastique Kunststoffbox Caja de Plástico	Sachet Plastique Kunststoffbeutel Bolsa de Plástico	Boîte en papier Papierverpackung Caja de papel		
Appearance				Appearance			Application		
Apparence Aussehen Apariencia				Apparence Aussehen Apariencia				Apparence Aussehen Apariencia	
28 HOB-1	HOB-1	1	6x40	HOB-1		1	6x40	HOK-1	
29 HOB-2	HOB-2/5	5	24x10	HOB-2		5	24x10	SK-4/HOK, SK-4, SK-4/green, SK-5, SK-9, SK-3, UTC-1	
30 ESKB-1	ESKB-1/2B	2	6x40	ESKB-1		2	6x40	ESK-1	
31 SWB-5	SWB-5/1B	1	10x12	SWB-5		1	10x12	CS-5	
32 HSWB-1	HSWB-1/1B	1	6x20	HSWB-1		1	6x20	HSW-1, XH-1, XH-AL, H-1, NH-1	
33 KB	KB	25	6x40	KB		25	6x40	AK-1, AK-4, LTD-AK	
34 KB4-S	KB4-S/5	5	6x40	KB4-S		5	6x40	AK-4, LTD-AK	
	KB4-S/100	100	10x5	KB4-S		100	10x5		
35 KB4-R	KB4-R/5	5	6x40	KB4-R		5	6x40		
36 KB4-F	KB4-F/5	5	6x40	KB4-F		5	6x40		
37 KB4-NF	KB4-NF/5	5	6x40	KB4-NF		5	6x40	AK-4	
38 KB4-SC	KB4-SC/2	2	6x40	KB4-SC		2	6x40		
39 KB4-P	KB4-P/5	5	6x40	KB4-P		5	6x40		
40 KB4-NS	KB4-NS/3	3	6x40	KB4-NS		3	6x40		
41 KB4-WS	KB4-WS/3	3	6x40	KB4-WS		3	6x40	AK-5, AK-5/BLK, AK-5/BLU, AK-5/PIK	
42 KB-5	KB-5/30B	30	6x40	KB-5		30	6x40		
43 TSB-1	TSB-1	5	6x40	TSB-1		5	6x40		TS-1
44 COB-1	COB-1	15 (5x3)	6x40	COB-1		15 (5x3)	6x40		CMP-1, CMP-1/DX
45 MCB-1	MCB-1	5	6x40	MCB-1		5	6x40	MC-45	
46 PB-800	PB-800	3	6x40	PB-800		3	6x40	PC-L	
47 PB-450	PB-450	5	6x40	PB-450		5	6x40	PC-S	
48 RB60	RB60-1	1	6x40	RB60		1	6x40	RTY-3/G, RTY-3/DX	
49 RB60H	RB60H-1	1	3x40	RB60H		1	3x40	RTY-3/G, RTY-3/DX	
50 CHB	CHB-1	1	6x20	CHB		1	6x20	CHN-1	
51 RB45	RB45-1	1	6x80	RB45		1	6x80	RTY-2/G, RTY-2/DX, RTY-2/NS, RTY-2/C, RTY-2C/YEL, RTY-2C/PIK, RTY-2C/NBL, 45C	
	RB45-10	10	6x10	RB45		10	6x10		
52 RB45H	RB45H-1	1	6x20	RB45H		1	6x20	RTY-2/DX	
53 WAB45	WAB45-1	1	6x40	WAB45		1	6x40		
54 PIB45	PIB45-1	1	6x40	PIB45		1	6x40	RTY-1/C, PRC-3/C	
55 RB28	RB28-2	2	6x80	RB28		2	6x80		
	RB28-10	10	6x10	RB28		10	6x10		
56 PRB28	PRB28-2	2	6x40	PRB28		2	6x40	CMP-3, RTY-4	
57 RB18	RB18-2	2	6x80	RB18		2	6x80		
58 PRB18	PRB18-2	2	6x80	PRB18		2	6x80	RTY-4	
59 TB-45	TB-45	4	6x40	TB-45		4	6x40	T-45	
60 BS	BS-10B	10	6x20	BS		10	6x20	XSR-200, XSR-300, XSR-600	
61 BS08	BS08-6B	6	6x20	BS08		6	6x20		
62 BSF	BSF-6B	6	6x10	BSF		6	6x10		
63 BTB-1	BTB-1	3	6x40	BTB-1		3	6x40	BTC-1, BTC-1/DX	
64 SKB-16	SKB-16/10	10	6x10	SKB-16		10	6x10	SK-16	
65 GSB-1S	GSB-1S	30	6x6	GSB-1S		30	6x6	GSR-1, GSR-2	
66 GSB-2S	GSB-2S/6B	6	6x40	GSB-2S		6	6x40	GSR-2	



MANUFACTURED BY  
**OLFA CORPORATION**  
MANUFACTURER AND EXPORTER

Higashi-Nakamoto 2-11-8, Higashinari-Ku,  
OSAKA 537-0021, JAPAN

Phone: +81-(0)6-6972-8104

F a x: +81-(0)6-6972-7400

<https://www.olfaco.jp/en/>

2025 02502-SN

OLFA reserves the right to discontinue the sale of any products and to change the specification without prior notice to you or any other third party.  
OLFA shall not be liable for any claims or damages arising in connection with products sold prior to such change being implemented.

Entire contents copyright OLFA CORPORATION All rights reserved.  
OLFA®, X-Design® and SPEED BLADE® are registered trademarks of OLFA CORPORATION